



Fire Protection for
Process Equipment

hydrocarbon and
jet fire protection

Contents

Introduction	3	FireMaster Instrument cable tray fire protection	48
		30 minute hydrocarbon fire protection	51
		Weather proofing system	52
		Cable tray fire protection fire testing and certification	53
Hydrocarbon, Jet Fire and Explosion testing and certification	5		
Classification	6		
FireMaster® Pipework Jet and Hydrocarbon fire protection	10	FireMaster vessel fire protection system	56
Jet fire protection of steel piping	11	Hydrocarbon fire protection for process vessels	57
Examples of FireMaster JetWrap system on bends	17		
Foamglass pipe system	19	Explosion resistance testing of FireMaster Process Equipment	
A guide to specification and certification	21	fire protection systems	62
Acoustic insulation properties of FireMaster pipe fire protection system	24		
FireMaster Rigid Enclosure System (RES)	30	FireMaster structural steel fire protection	66
Valve and actuator fire protection	38	Fire insulation to steel beams and columns	67
		Structural steel fire protection system - Guide to Specification and Certification	71
		SectionWizard software	74
FireMaster Flexible Enclosure System (FES)	40		
Fire test performance of FireMaster Flexible Enclosure System	47		

Introduction

This manual presents Thermal Ceramics FireMaster® fire insulation solutions for protection of critical process equipment including the protection of structural support steelwork.

Passive fire protection is designed to protect critical processing and safety equipment in the event of a fire for long enough to allow a safe and controlled plant shut down. It slows the spread of jet and pool fires and delays the possibility of equipment malfunction, allowing personnel more time to escape.

On offshore facilities and petrochemical processing sites, passive fire protection is typically specified for equipment required for emergency shutdown and process equipment that must remain intact during a fire. Critically, the protection specification should ensure that the equipment remains below its failure temperature throughout the period specified so that it continues to operate normally and can play its part in effecting a controlled shutdown.

Thermal Ceramics offers a range of products and systems for fire protection of process equipment in chemical processing and oil and gas production facilities both onshore and offshore. These systems provide fire insulation to critical plant or services when exposed to hydrocarbon pool or jet impingement fires.

In addition to process fire protection, we also supply systems for fire rated divisions such as bulkheads, decks and fire walls from A15 up to H120 and J30. Details of those systems can be found in our 'Marine and Offshore Fire Divisions' manual.

This manual contains details of the following systems:

Application	System	Performance / Testing	Page
Pipework	FireMaster Blanket and Microporous insulation system	Hydrocarbon Fire Protection EN 13381-4 up to 200 minutes Jet Fire Protection ISO 22899-1 for up to 180 minutes Explosion resistance to 0.5 bar	11 - 29
	FireMaster FES Flexible Enclosure System	Jet fire protection to ISO 22899-1 for up to 150 minutes	
	FireMaster Blanket with cellular Foamglas	Jet fire protection 60 minutes to OTO 95-634 Explosion resistance to 0.7 bar	
Valves, actuators and flanges	FireMaster RES - Rigid Enclosure System	Jet fire protection ISO 22899-1 up to 60 minutes Explosion resistance to 0.5 bar	31 - 48
	FireMaster FES - Flexible Enclosure System	Jet fire protection ISO 22899-1 up to 175 minutes	
Instrument cable trays	FireMaster Cable Tray System	Hydrocarbon Fire protection for 30 minutes ASTM 1725-95	49 - 55
Process vessels	FireMaster Vessel System	Jet fire protection to ISO 22899-1 for up to 180 minutes Explosion resistance to 0.5 bar	57 - 62
	FireMaster FES Flexible Enclosure System	Jet fire protection to ISO 22899-1 for up to 175 minutes	
Structural steel	FireMaster Marine Plus blanket	Hydrocarbon Fire Protection up to 120 minutes EN 13381-4 Cellulosic Fire Protection up to 180 minutes EN 13381-4	67 - 74

Thermal Ceramics offers a range of products and systems for fire protection of process equipment in chemical processing and oil and gas production facilities both onshore and offshore.



Hydrocarbon and jet fire testing and certification

This manual presents a number of systems for fire protection against hydrocarbon and jet impingement fires. The subject of fire testing of such systems is not always well understood as the standards are less prescriptive than those found in industries such as construction or marine. The purpose of this section is to highlight some significant factors that should be borne in mind when evaluating fire insulation systems for process equipment.

Performance requirements

Commonly used standards for the specification or the fire testing of passive fire protection systems are usually based on ensuring the critical temperatures of structural elements such as steelwork or fire walls are not exceeded. Whereas structural steel sections may have a critical temperature of typically 400°C, the critical temperature limits of processing equipment such as valves, flanges or actuators is often much lower; for example less than 150°C.

It is therefore advisable to ensure that systems offered for the fire protection of critical components are independently tested and approved to provide adequate protection, i.e. that they ensure the specified critical temperature of the component will not be exceeded. In addition, all components (fixings, sealants etc) of the fire insulation system as fitted on site should also have been demonstrated to be suitable through relevant fire testing. A fire test on any fire insulation system demonstrates both the integrity of the system and its insulation capability.

Careful consideration must be made of the limitations of size or mass of the contents of the equipment protected by the system, as changes to the fire insulation used may be required for equipment that have a lower critical temperature or less heat capacity. In such cases, certification for the fire insulation system may place a maximum limit of the surface area to mass relationship (or 'section factor') of the item protected or alternatively encompass an approved method for changing the insulation specification to suit contents with varying mass, section factors or critical temperatures.

Design fires

Hydrocarbon fires have varying heat flux depending on the nature of the fire. Standard temperature/time relationships are incorporated into fire test standards to simulate hydrocarbon fires so that furnace testing of protection systems can be carried out. This aids reliability of testing. In some cases alternative hydrocarbon fire scenarios other than standard temperature/ time relationship may be appropriate.

The UK Dept. of Energy, Norwegian Petroleum Directorate, EN 1363-2:1999, ISO 834-3, ASTM 1529 and UL 1709 are some commonly used hydrocarbon fire curves.

Figure 1, see page 6, compares several design fire scenarios.

Jet fires are acknowledged to have varying intensity and unlike with hydrocarbon fires no 'standard' jet fire specification exists. Whereas hydrocarbon fires are defined as temperature/ time relationships, jet fire exposures are most often specified using heat flux values.

The heat flux obtained in jet fires is not a specified value of the ISO 22899-1 jet fire test standard which is designed to provide a uniform fire test method, repeatable with a degree of reliability based on a specified propane flow rate of 0.3kg/s providing fuel for the jet flame.

It is estimated that the heat flux obtained in the ISO 22899-1 test is on average 240 kW/m² at the back wall of the test box, compared to an assumed heat flux of approximately 200 kW/m² estimated in a hydrocarbon furnace test, see page 6. Within ISO 22899-2 peak heat fluxes of 300 kW/m² are acknowledged as possible in the ISO 22899-1 standard jet fire test.

In some cases, fire tests utilising higher heat fluxes than 240 kW/m² may be proposed. These fire tests inevitably require the modification of the test equipment specified in ISO 22899-1 in order to obtain higher heat fluxes resulting in a 'non-standard' fire test being carried out. Caution should be applied when assessing such fire tests as they depart from the test method specified in the ISO 22899-1 standard.

Classification

ISO 22899-1 and ISO 22899-2 contain fire test procedures for fire testing equipment in jet fire exposure conditions. Classification of systems tested is specific to the intended use application and takes the following form:

JF/Application/Critical Temperature/Time to Critical Temperature

Example: Insulation thickness for structural steel 400°C critical temperature protected for 120 minutes would be classified as:

JF/Structural Steel/400°C /120 minutes

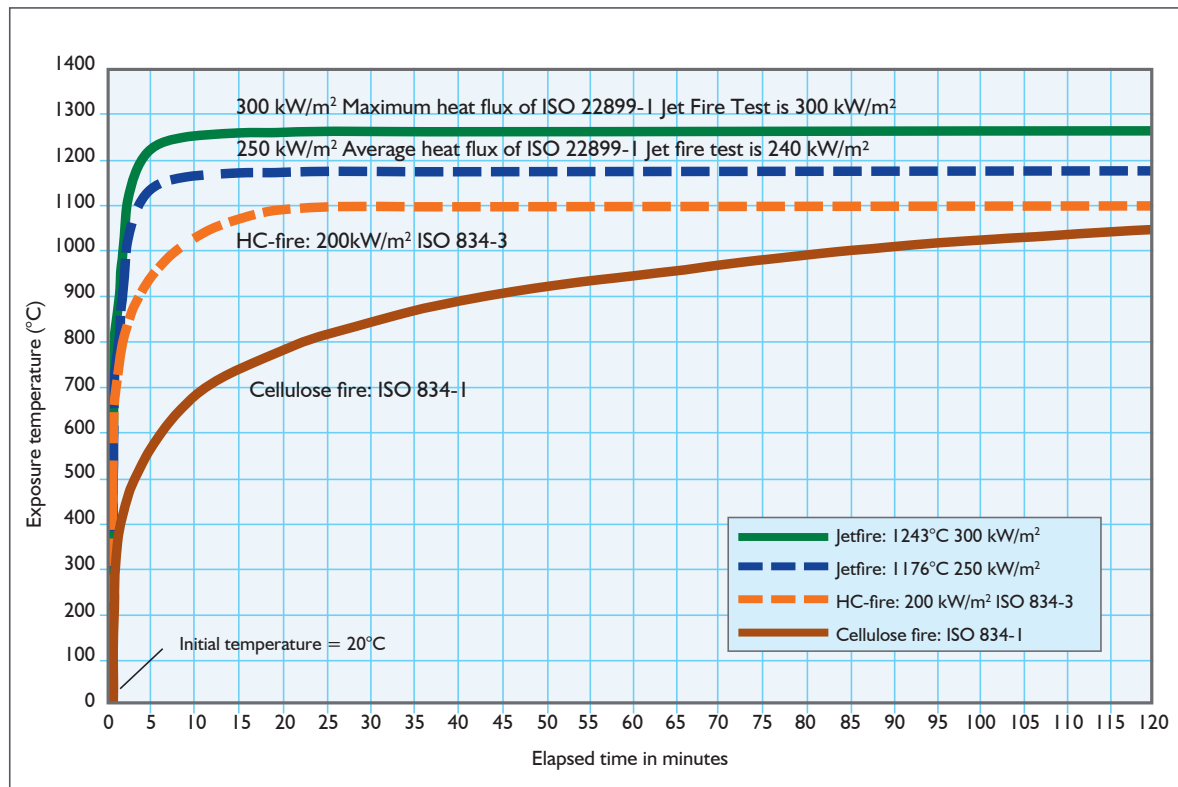

Figure 1: Various possible fire scenarios

Combined Jet and Hydrocarbon Fires

Jet fire tests may be carried out for extended time periods (60 and 120 minutes are common) but often on offshore facilities, the design fire scenario consists of an initial jet fire (possibly following an explosion) of much shorter duration followed by a longer-period, lower-intensity, hydrocarbon pool fire. The ISO 22899-2 standard includes guidance on how to assess insulation requirements for these combined jet and hydrocarbon fire scenarios.

Section 9 of the standard explains the use of 'section factor' versus insulation thickness tables for specific critical temperatures and fire duration times. These tables are derived from hydrocarbon fire tests. For passive insulation materials, Jet fire protection usually

requires the use of more insulation than is required for hydrocarbon fire protection. ISO 22899-2 introduces an 'erosion factor' concept to allow for extra material requirements in jet versus hydrocarbon fires.

This 'erosion' factor when used with passive insulation materials is the extra thickness required to obtain the same insulation performance from a protection system in a jet fire test as is obtained in a hydrocarbon furnace test. It is then used in combination with the section factor versus thickness tables for hydrocarbon fires to determine the required thickness for the combined fire.

For example, if a 15 minute jet fire followed by a 30 minute pool fire is specified then the overall fire duration is taken as 45 minutes. The thickness of material (e.g. 50mm) required to protect a specimen of the desired section factor for 45 minutes is then determined from the section factor versus thickness table for a hydrocarbon fire. The 'erosion factor' for a 15 minute jet fire test is determined (e.g. 5mm) and this is added to the furnace test thickness to give a total required thickness (50+5 = 55mm). A detailed example of this calculation can be found on page 21.

An explanation of section factors and their calculation can be found in this manual in the pipe fire protection and structural steel protection application sections see pages 21-23.

Combined fire and explosion

In the event of an accidental release of flammable gas or volatile liquid on an installation there is the potential for an explosion. It is possible that the passage of flame in the explosion will ignite a release of flammable gas resulting in a fire. In order to protect process plant and structural members from the effects of the overpressure produced by the gas explosion and any subsequent fire it is common practice to use passive fire protection. In the event that a gas explosion precedes a fire, the passive fire protection must remain intact after the gas explosion.

Explosion testing of passive fire protection systems is carried out to assess their integrity after exposure to explosion pressures. In the absence of international test standards detailing the protocol of such tests, the common approach is to make an evaluation of the integrity of a sample of the passive fire protection system after blast exposure in order to evaluate if it can be assumed to provide the same degree of fire resistance as one not exposed to blast pressure.

The various potential explosion scenarios possible require careful consideration as both the degree and duration of over-pressure must be included in testing. As these vary considerably in practice, available test data must be carefully assessed against design conditions.

For details of the explosion testing of FireMaster® Process Equipment fire protection systems see page 62-65.

Figure 2: Example of gas explosion test peak pressure and duration values

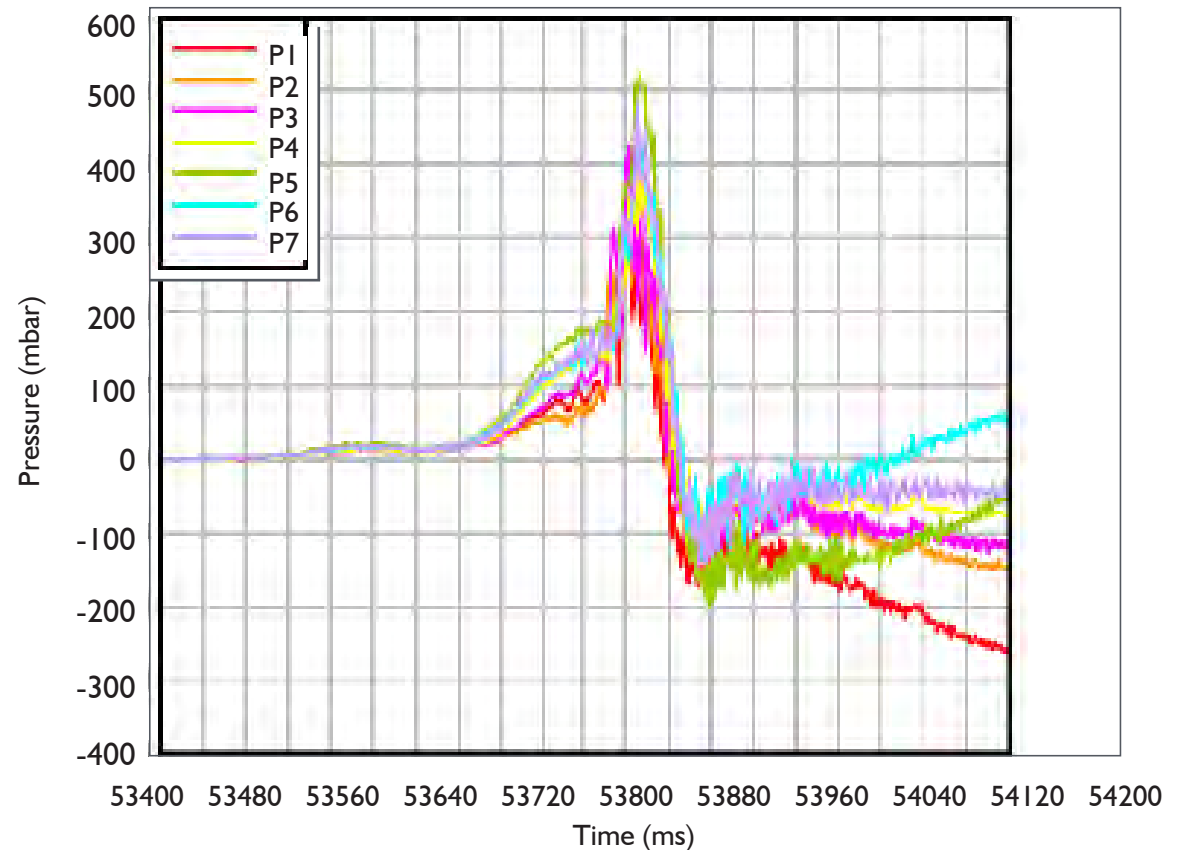

Blast Load Profiles

The diagram below shows the idealised profile of pressure in relation to time for the case of a free air blast wave. The pressure is initially equal to the ambient pressure and it undergoes an instantaneous increase to a peak pressure at the arrival time.

The time needed for the pressure to reach its peak value is very small and for design purposes it is assumed to be equal to zero. The peak pressure is also known as peak overpressure. The value of the peak overpressure as well as the velocity of propagation of the shock wave decrease with increasing distance from the detonation centre. After its peak value, the pressure decreases with an exponential rate until it reaches the ambient pressure; this is the positive phase duration.

After the positive phase, the pressure becomes smaller than the ambient value (this is the negative phase), finally returning to ambient pressure. The negative phase is longer than the positive one. During this phase, structures and passive fire protection systems are subjected to suction forces.

Blast testing investigates the response of passive fire protection systems to both the peak overpressure and suction forces resulting from explosions. The values of peak overpressure and positive duration are important in specifying explosion test scenarios.

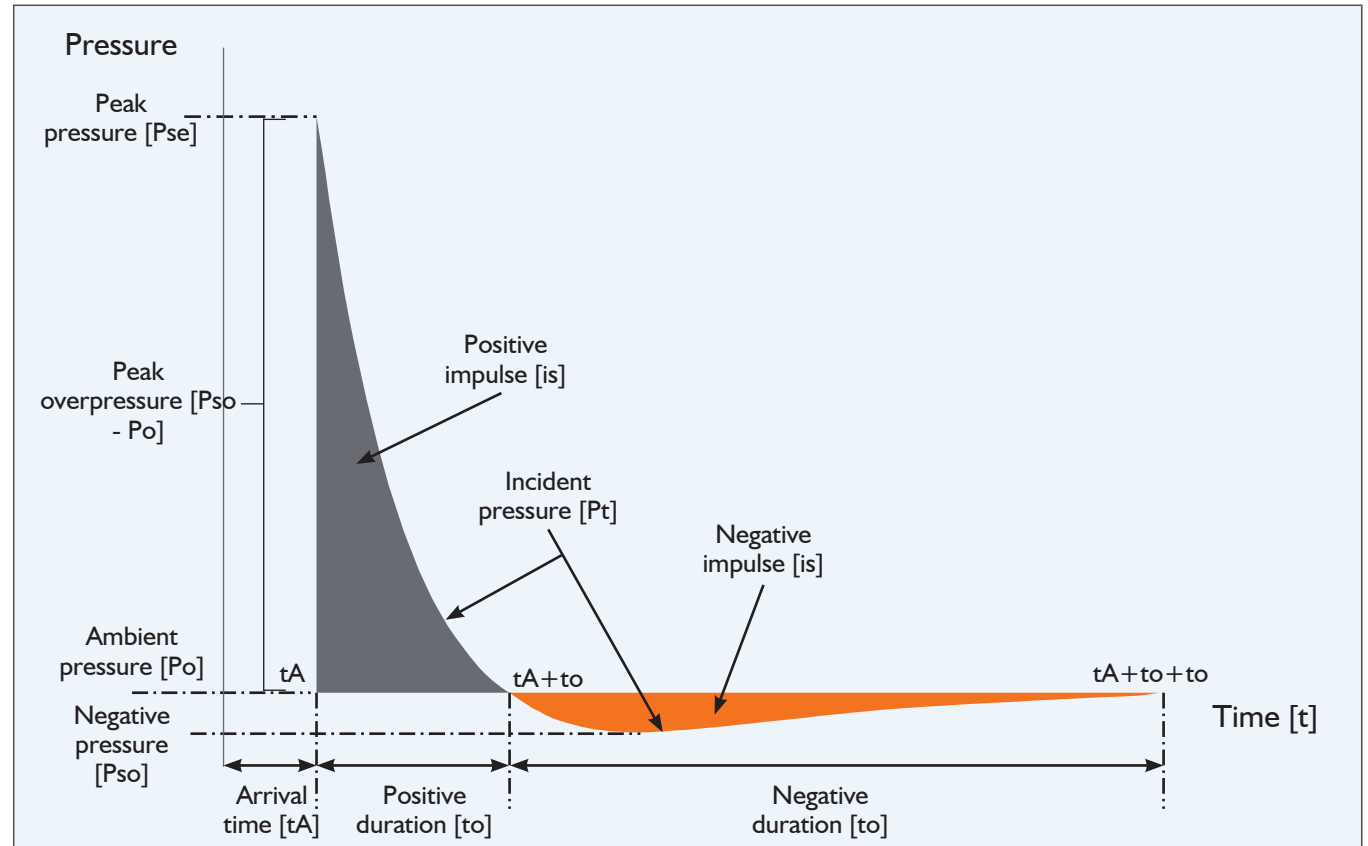



FIREMASTER[®]



FireMaster[®] Pipework Jet and Hydrocarbon fire protection

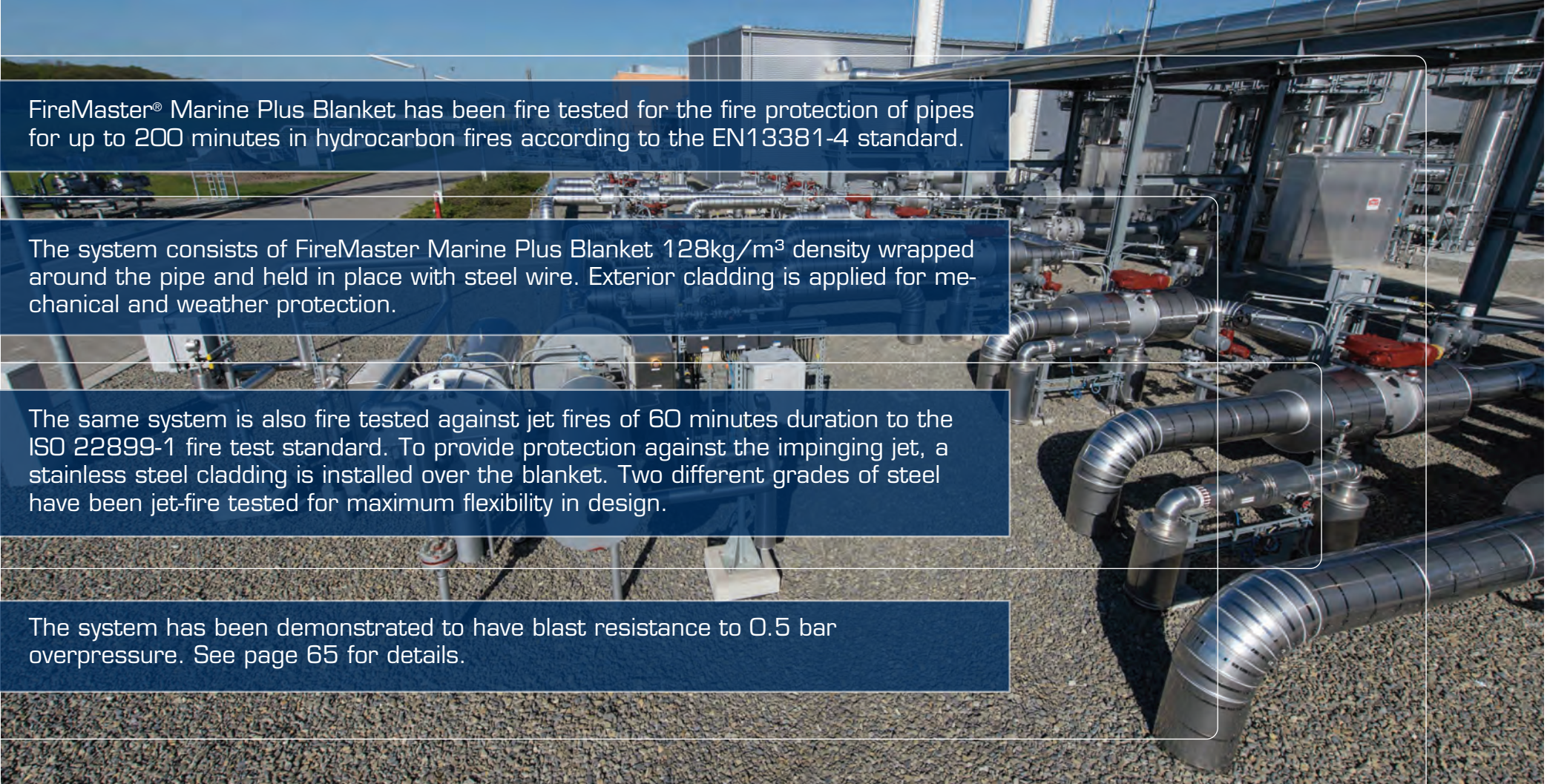

Jet fire protection of steel piping

A photograph of an industrial facility showing a complex network of steel pipes and machinery. Several large pipes are wrapped in a silver, reflective fire protection blanket. The background shows a clear blue sky and industrial buildings.

FireMaster® Marine Plus Blanket has been fire tested for the fire protection of pipes for up to 200 minutes in hydrocarbon fires according to the EN13381-4 standard.

The system consists of FireMaster Marine Plus Blanket 128kg/m³ density wrapped around the pipe and held in place with steel wire. Exterior cladding is applied for mechanical and weather protection.

The same system is also fire tested against jet fires of 60 minutes duration to the ISO 22899-1 fire test standard. To provide protection against the impinging jet, a stainless steel cladding is installed over the blanket. Two different grades of steel have been jet-fire tested for maximum flexibility in design.

The system has been demonstrated to have blast resistance to 0.5 bar overpressure. See page 65 for details.

Our systems provide a lower-cost alternative to custom-made jacket systems and are:

- Lightweight
- Easy to install
- Easy to engineer and modify on site, requiring minimal site surveying
- Cost-effective

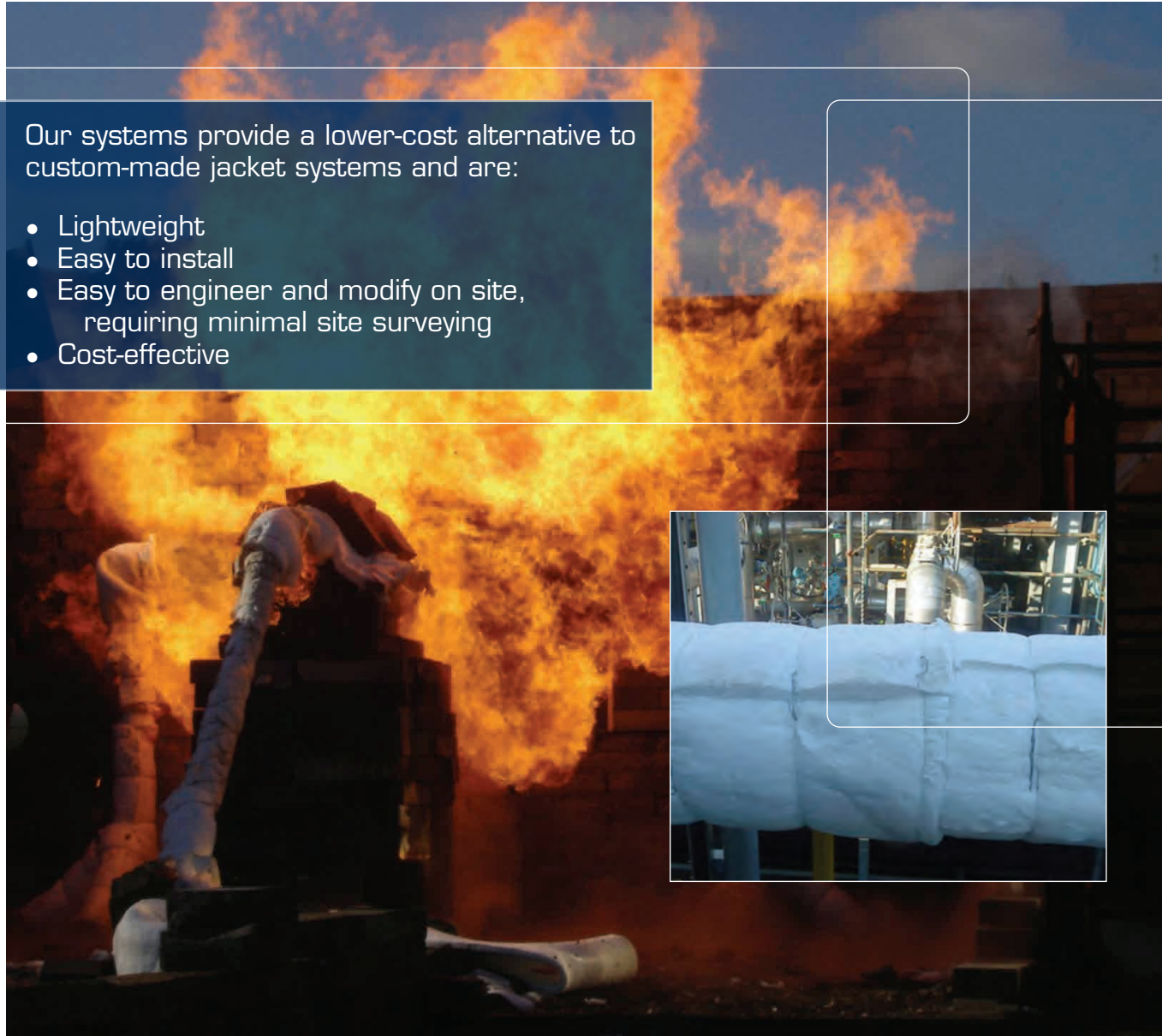

Jet fire protection of steel piping

Steel pipe system. Explosion resistance to 0.5 bar

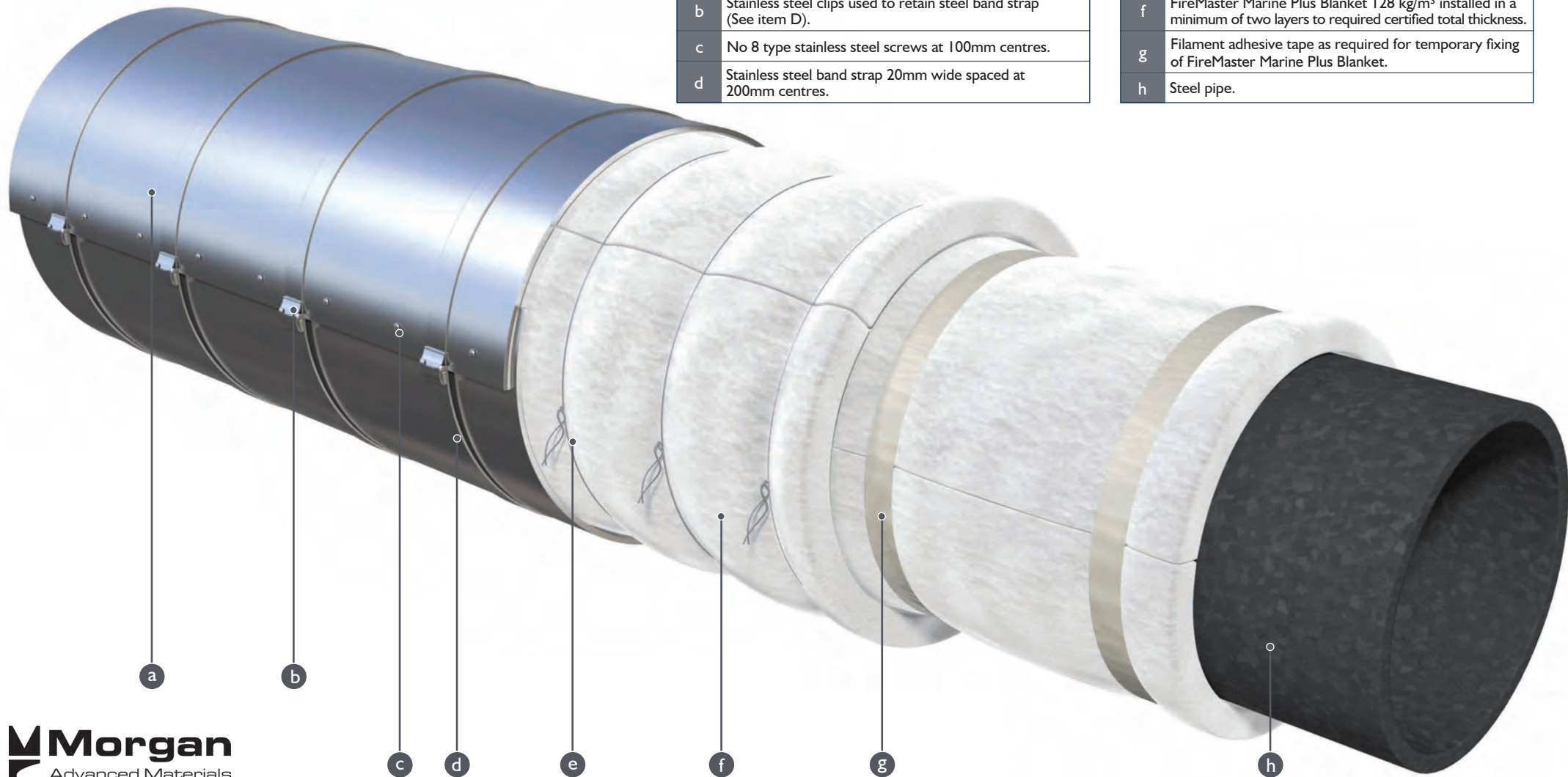

Steel pipe system - detail view

a	Steel Cladding - for jet fire either: 1. 316 grade 0.7mm 2. 304 grade 0.6mm
b	Overlap on steel cladding of 75mm sealed with Dow Corning FireStop 700 mastic or equivalent.
c	No 8 type stainless steel screws at 100mm centres.
d	Stainless steel band strap 20mm wide spaced at 200mm centres.
e	Steel tie wire for retention of FireMaster® Marine Plus Blanket spaced at nominal 50mm from blanket edge and at centre of blanket with maximum of 300mm spacing.
f	FireMaster Marine Plus Blanket 128 kg/m ³ installed in a minimum of two layers to required certified total thickness.

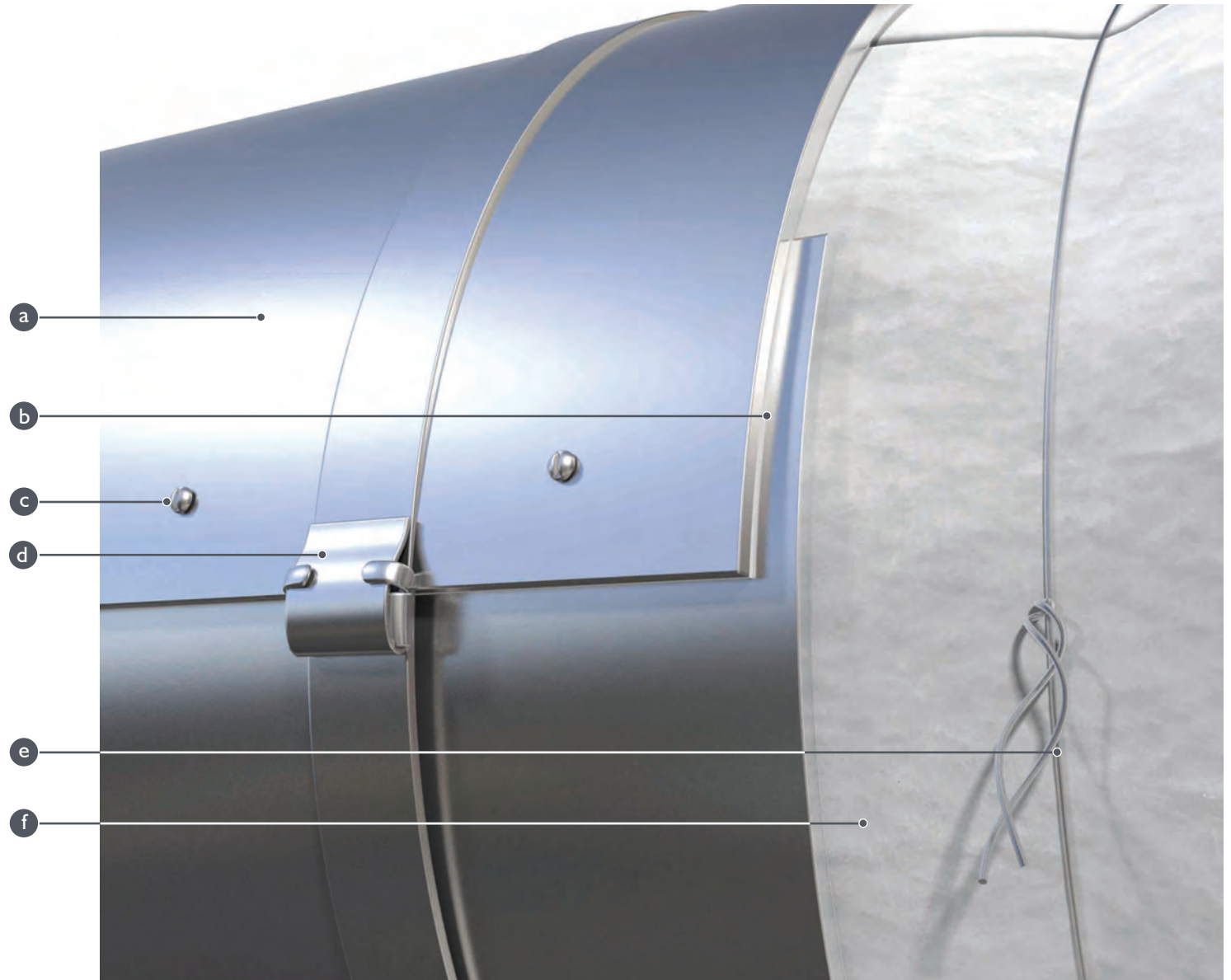

180 minute Jet Fire Protection System for steel pipes

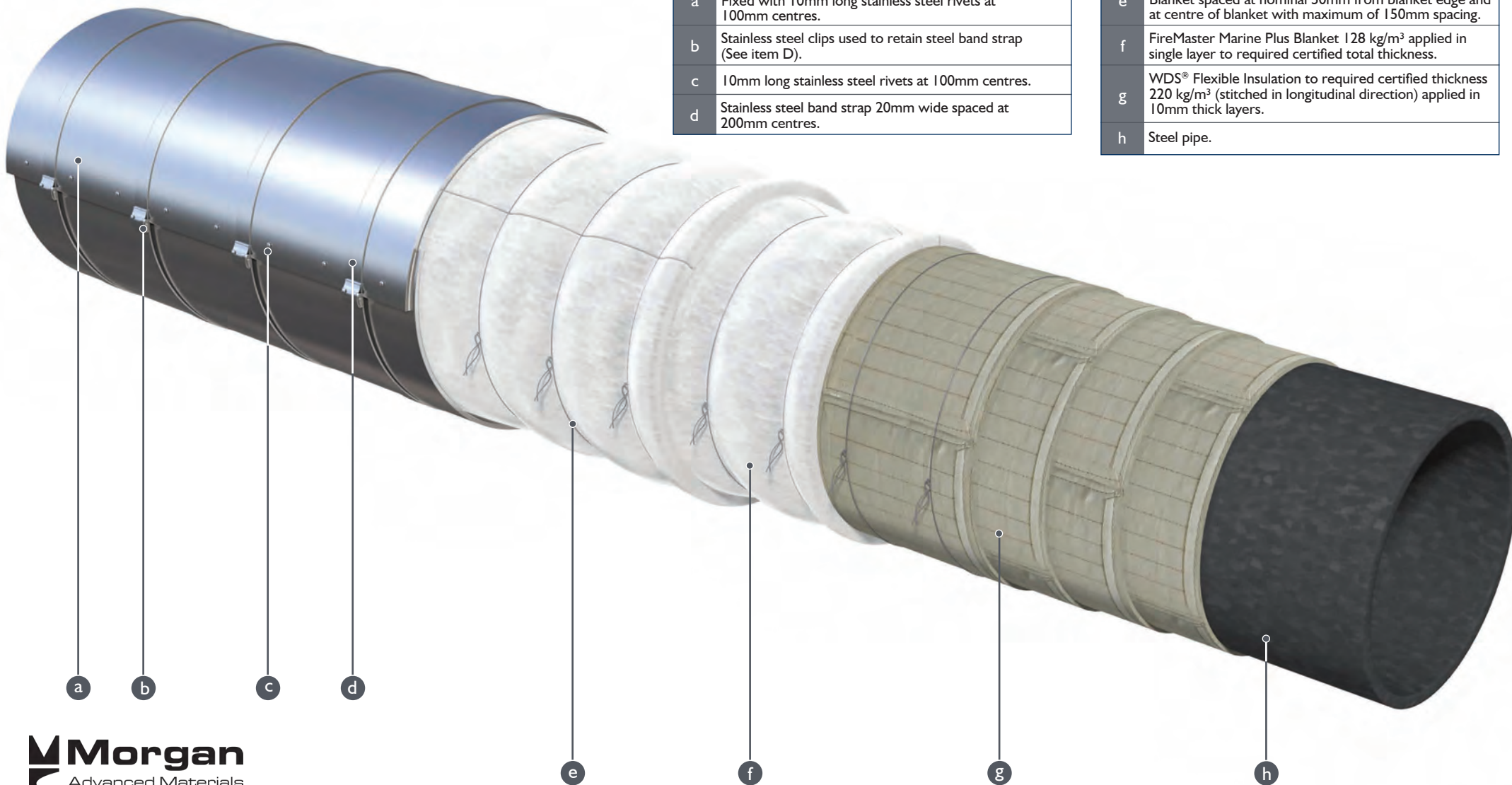

a	Steel Cladding - for jet fire : 304 grade 0.6mm Fixed with 10mm long stainless steel rivets at 100mm centres.
b	Stainless steel clips used to retain steel band strap (See item D).
c	10mm long stainless steel rivets at 100mm centres.
d	Stainless steel band strap 20mm wide spaced at 200mm centres.

e	Steel tie wire for retention of FireMaster® Marine Plus Blanket spaced at nominal 50mm from blanket edge and at centre of blanket with maximum of 150mm spacing.
f	FireMaster Marine Plus Blanket 128 kg/m ³ applied in single layer to required certified total thickness.
g	WDS® Flexible Insulation to required certified thickness 220 kg/m ³ (stitched in longitudinal direction) applied in 10mm thick layers.
h	Steel pipe.

Continuous wrap alternative

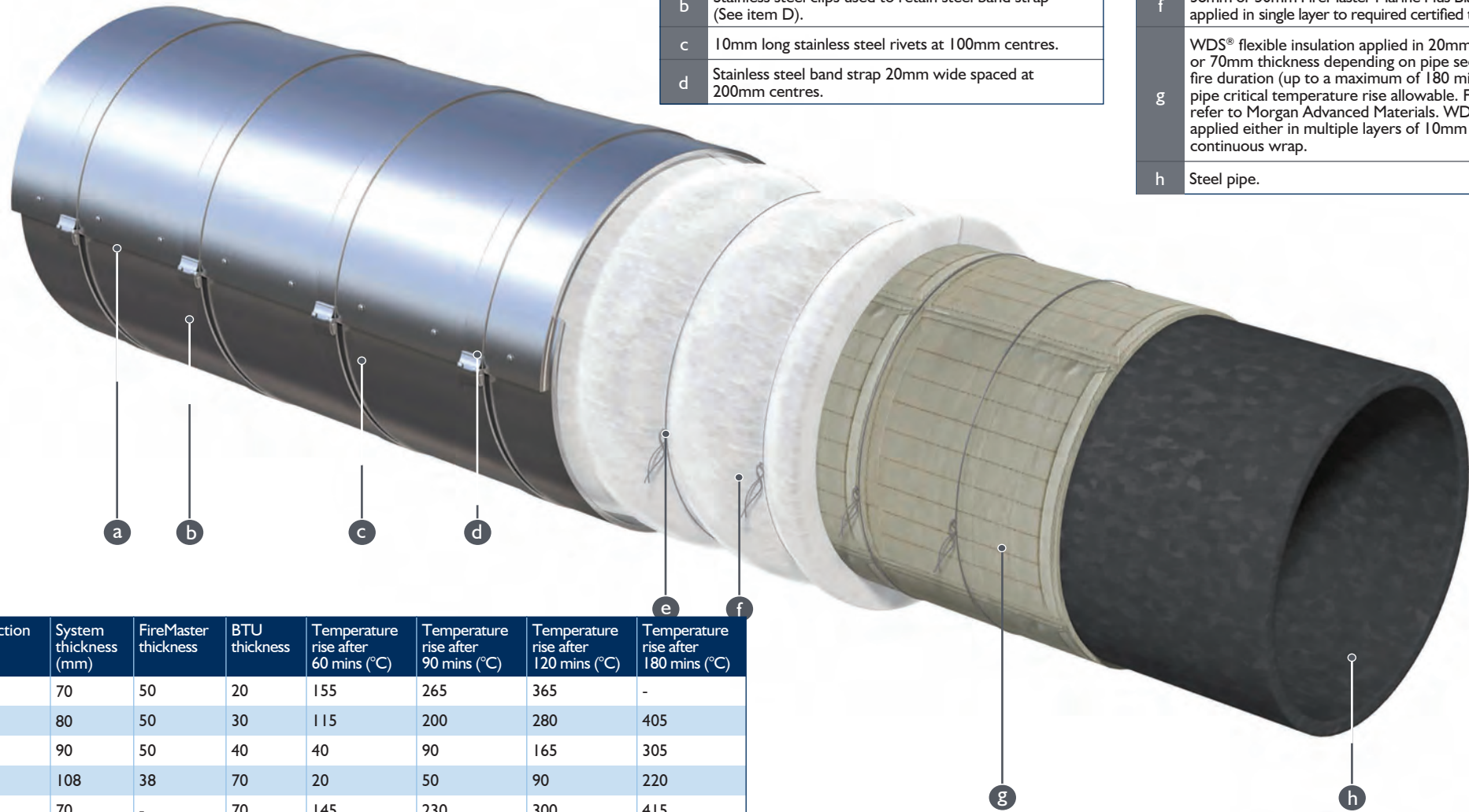

a	Steel Cladding - for jet fire : 304 grade 0.6mm Fixed with 10mm long stainless steel rivets at 100mm centres.
b	Stainless steel clips used to retain steel band strap (See item D).
c	10mm long stainless steel rivets at 100mm centres.
d	Stainless steel band strap 20mm wide spaced at 200mm centres.

e	Steel tie wire for retention of FireMaster® Marine Plus Blanket spaced at nominal 50mm from blanket edge and at centre of blanket with maximum of 150mm spacing.
f	38mm or 50mm FireMaster Marine Plus Blanket 128 kg/m ³ applied in single layer to required certified total thickness.
g	WDS® flexible insulation applied in 20mm, 30mm, 40mm or 70mm thickness depending on pipe section factor, fire duration (up to a maximum of 180 minutes) and pipe critical temperature rise allowable. For full details refer to Morgan Advanced Materials. WDS Flexible is applied either in multiple layers of 10mm or as a continuous wrap.
h	Steel pipe.

Pipe section factor (m ⁻¹)	System thickness (mm)	FireMaster thickness	BTU thickness	Temperature rise after 60 mins (°C)	Temperature rise after 90 mins (°C)	Temperature rise after 120 mins (°C)	Temperature rise after 180 mins (°C)
115	70	50	20	155	265	365	-
113	80	50	30	115	200	280	405
120	90	50	40	40	90	165	305
206	108	38	70	20	50	90	220
254*	70	-	70	145	230	300	415
345	78	38	40	155	310	-	-

* tested as a drain plug detail see Type Approval Certificate for details

Examples of FireMaster® JetWrap system on bends

Pipe bends



Pipe bends - detail view

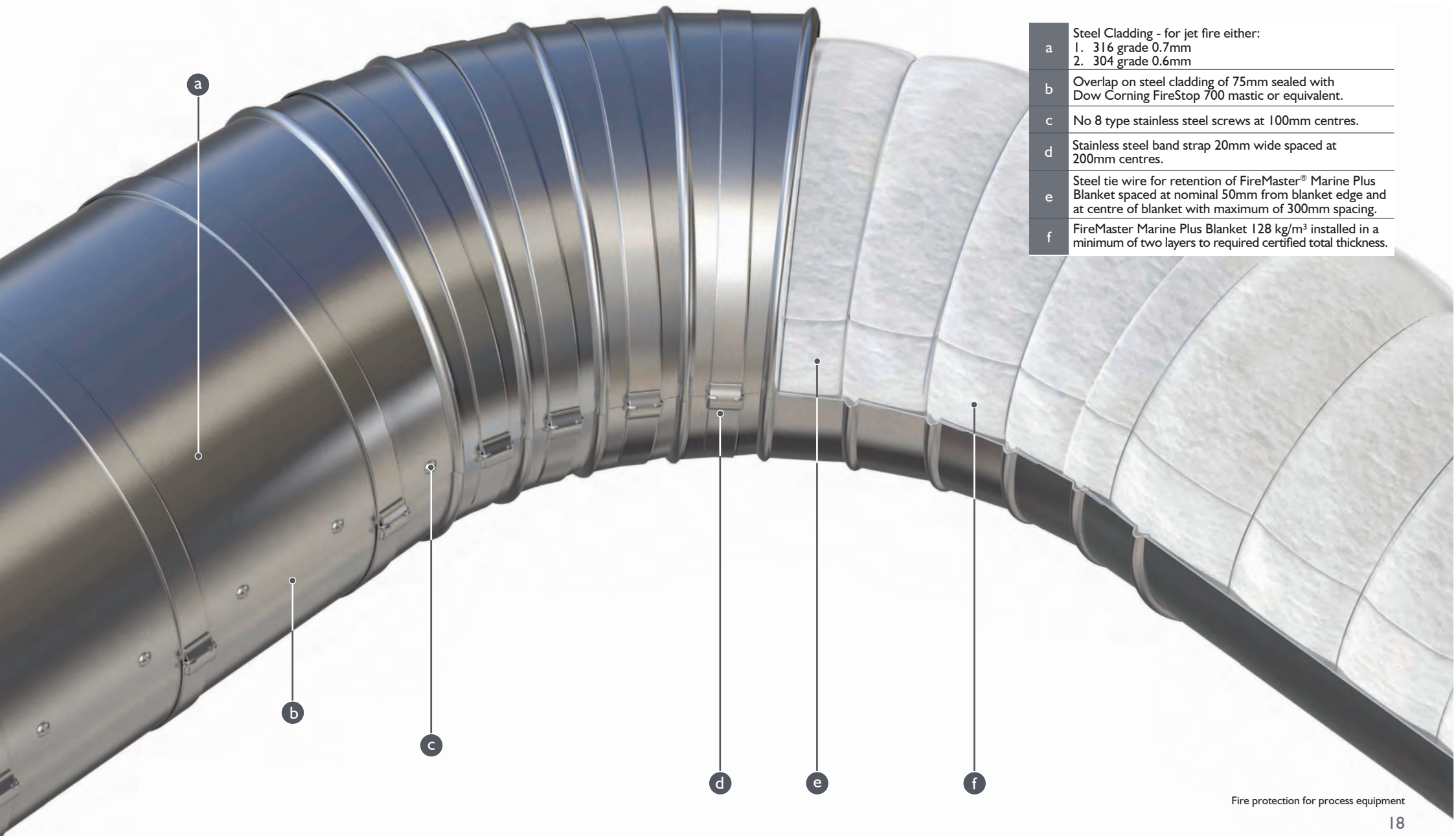

a	Steel Cladding - for jet fire either: 1. 316 grade 0.7mm 2. 304 grade 0.6mm
b	Overlap on steel cladding of 75mm sealed with Dow Corning FireStop 700 mastic or equivalent.
c	No 8 type stainless steel screws at 100mm centres.
d	Stainless steel band strap 20mm wide spaced at 200mm centres.
e	Steel tie wire for retention of FireMaster® Marine Plus Blanket spaced at nominal 50mm from blanket edge and at centre of blanket with maximum of 300mm spacing.
f	FireMaster Marine Plus Blanket 128 kg/m ³ installed in a minimum of two layers to required certified total thickness.

Jet fire protection of steel piping

Foamglass pipe system. Blast resistance : 0.7 bar

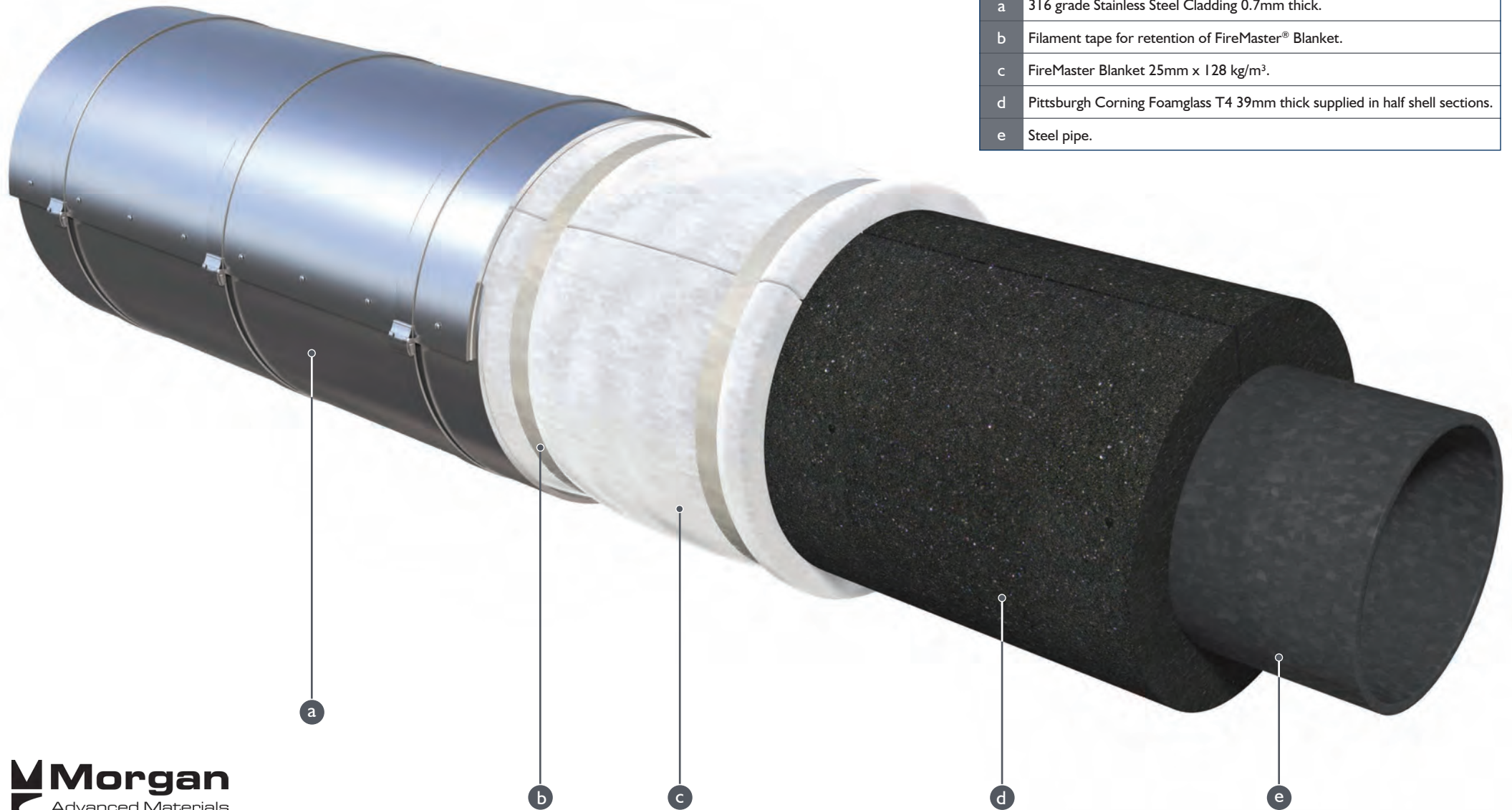

Foamglass pipe system - detail view

a	316 grade stainless steel cladding 0.7mm thick.
b	Overlap on steel cladding of 75mm sealed with Dow Corning FireStop 700 mastic or equivalent.
c	No 8 type stainless steel screws at 100mm centres.
d	Stainless steel band strap 20mm wide spaced at 200mm centres.
e	FireMaster® Blanket 25mm x 128 kg/m ³ .
f	Filament tape for retention of FireMaster Blanket.

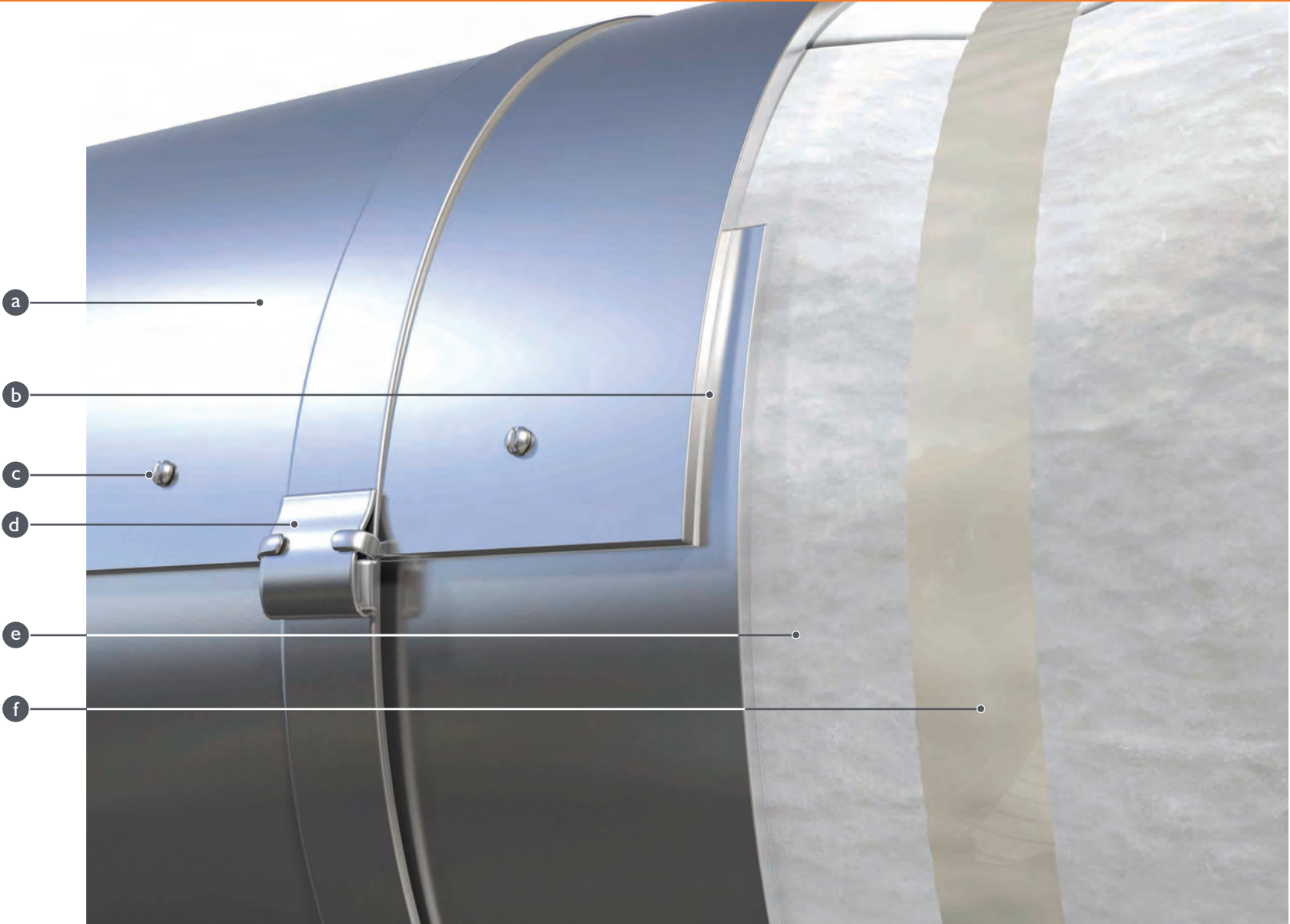

FireMaster[®] pipe fire protection system

A guide to specification and certification

The thickness of insulation that is required to be applied to pipework to provide fire protection will depend on a number of factors. These are:

1. Fire load and duration
2. Critical temperature specified for the pipe; i.e. the maximum permitted temperature for the pipe during the fire
3. The 'section factor' of the pipe; a relationship of external pipe surface perimeter and pipe wall thickness
4. The initial operating temperature of the pipe

These factors are very important in design of pipe fire insulation systems.

Critical pipe temperature

Pipework is normally insulated against fire to maintain its temperatures below 400°C, the limit usually applied for structural steel, in order to prevent rupture or collapse. Other temperature limits than this may also be applied. The thickness of fire insulation that must be applied will vary with the pipe critical temperature; increasing as the critical temperature decreases for the same size of pipe.

Section factor

The section factor relates the surface area of the pipe exposed to fire to the amount of steel in the wall of the pipe available to absorb heat from the fire.

As steel offers a large 'heat sink' effect, increasing wall thickness provides an increased mass of steel to be heated, resulting in a slower rise in temperature. The rate of heat increase also depends on how much heat is input into the pipe. This will vary with the surface area available to absorb heat. As pipe diameter increases, the heated surface area increases. As wall thickness increases, the volume of steel available to absorb heat increases.

The section factor of a pipe is calculated by dividing the outside external pipe surface perimeter by the cross-sectional area of the wall.

Example:

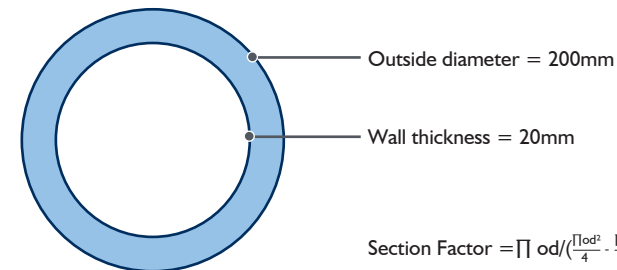

The table below illustrates the effect of section factor on insulation thickness for two different sized pipes:

Pipe serial number	Section factor (m ⁻¹)	Insulation thickness required to maintain pipe temperature to 400°C for one hour in a hydrocarbon fire
6 inch schedule 120	77	25mm
3 inch schedule 40	205	75mm

Fire testing of pipe fire insulation is designed to relate section factor to insulation thickness for a variety of failure temperatures and this requires a large variety of pipes to be tested. FireMaster Marine Plus Blanket has been fully tested on 13 pipes in order to generate the required thickness tables in accordance with Annex E4 of EN 13381-4 fire test procedure for structural steelwork.

A guide to specification and certification

Fire load and duration

The heat flux or temperature to which the pipe is exposed will influence the thickness of insulation required for fire insulation. In general a jet fire is expected to have a higher heat flux than a hydrocarbon pool fire and therefore more insulation will be required when insulating a pipe against a jet fire than a hydrocarbon pool fire.

One problem when determining thickness requirements for jet fire insulation systems is that it is not practical to test the large variety of pipes required to obtain sufficient data to construct thickness versus section factor tables.

The common solution to this problem is to first test a sufficient variety of sizes in a furnace hydrocarbon fire test and then to select at least 2 of the pipes, identically insulated and subject them to a jet fire test. A relationship of temperature rises obtained in each fire scenario can then be made. More than 2 pipes may be required to be jet fire tested depending on the reliability of the relationship.

FireMaster® Marine Plus Blanket has been tested in accordance with this procedure and the test results used to construct a table of thickness requirement versus section factor for jet fire protection as well as hydrocarbon fire protection.

Thickness requirements jet fire and hydrocarbon fire

The tables opposite on page 24 compare the thickness requirements for jet and hydrocarbon fire protection of pipes of varying section factor for a critical temperature of 400°C assuming 60 minutes fire duration. For a full range of critical temperatures and time periods reference can be made to the Lloyds Register Type Approval certificate.

Additionally Morgan Advanced Materials provides a software package 'SectionWizard' to allow straightforward access to the fire test approved thickness data without the need to calculate section factors or look up tables. More details on SectionWizard can be found on page 74.

Guidelines on determination of the thickness of FireMaster Marine Plus Blanket required in combined jet and hydrocarbon fire protection of pipes ISO 22899-2 (Section 9) provides guidelines on determining the thickness of fire protection required for combined hydrocarbon and jet fires.

This is explained in more detail on page 6 of this manual. The following example illustrates this methodology for pipes fire protected with FireMaster Marine Plus Blanket.

Example: 30 minute initial jet fire followed by a 30 minute hydrocarbon fire - total fire duration of 60 minutes on a 6" (DN 150) schedule 40 pipe.

Using the fire test data on pipes insulated with FireMaster Marine Plus Blanket in hydrocarbon and jet fires, thickness v section factor tables are available for hydrocarbon and jet fires for a wide variety of pipe section factors.

These tables can be used to determine the necessary thicknesses used in the example below or (for maximum accuracy) through use of Morgan Advanced Materials "SectionWizard" Software.

A guide to specification and certification

ISO 22899-2 guidance on combined jet and hydrocarbon fires.

For the combined 30 minute jet fire followed by a 30 minute hydrocarbon fire, ISO 22899-2 guidance is as follows:

1. Select the insulation thickness required for 60 minutes hydrocarbon fire protection
2. Select the insulation thickness required for 30 minutes hydrocarbon fire protection
3. Select the insulation thickness required for 30 minutes jet fire protection
4. Calculate the “erosion factor” of jet versus hydrocarbon fire for the 30 minutes fire protection period by deducting the thickness in (2) from (3) above
5. Add this “erosion factor” to the thickness required for 60 minutes hydrocarbon fire selected in (1) above.

For the example above:

6” inch schedule 40 pipe – section factor 147m^{-1} assumed critical pipe temperature 400°C .

1. Thickness required for 60 minute Hydrocarbon fire = 51mm
2. Thickness required for 30 minute Hydrocarbon fire = 25mm
3. Thickness required for 30 minute Jet fire = 38mm ⁽¹⁾
4. “Erosion Factor” (See ISO 22899-2 Section 9) for 30 minute Jet fire = $38-25 = 13\text{mm}$
5. Thickness required for combined fire = $51 + 13 = 64\text{mm}$. The nearest standard thickness of FireMaster Blanket to this would be 75mm (25+50mm).

¹ For 400°C critical temperature on pipes in jet fires use the thickness required for a 200°C critical temperature of the corresponding pipe in a hydrocarbon fire in accordance with the Type Approval of FireMaster Marine Plus Blanket for pipes in jet and hydrocarbon fires. SectionWizard Software can be used to provide exact thickness values if standard tables are not available or do not provide sufficiently precise data.

Standard supplied thicknesses of FireMaster® Marine Plus Blanket required to limit the temperature rise of a steel pipe to 400°C in hydrocarbon and jet fires of 60 minutes duration.

Pipe section factor (m^{-1})	Hydrocarbon fire
≤ 75	25mm
76 to 105	38mm
106 to 145	50mm
146 to 200	63mm
201 to 275	75mm
276 to 400	88mm

Pipe section factor (m^{-1})	Jet fire
≤ 65	51mm
66 to 85	63mm
86 to 110	75mm
110 to 160	88mm
151 to 205	100mm

Acoustic insulation properties of FireMaster® pipe fire protection system

For insulation intended to be used on piping, sound transmission loss values must be measured on pipes insulated with the specific insulation system design.

Testing for sound transmission loss uses the ISO 15665:2011 insertion loss method. Pipes of 3 different diameters (DN100, DN300 and DN600) insulated with the insulation system are tested. Insertion losses of pipe sizes up to DN1000 can then be assessed in accordance with ISO 15665.

The basic concept of insertion loss testing is straightforward. "Pink noise" in 1/3 octave band over a frequency range of 50 to 10,000Hz is introduced into the 3 pipes which are located in an anechoic chamber. The sound transmission from each pipe into the chamber is then measured. The test is run firstly on a set of uninsulated pipes and then on a set of pipes fitted with the insulation system being investigated. Sound transmission values for

the uninsulated and insulated pipes can then be compared to obtain the sound reduction value of the insulation system. The general arrangement of the test is shown in the drawing below.

Test Performance of FireMaster Pipe Fire Protection System

A series of tests have been run on the FireMaster Jet Fire pipe fire protection system design. These have investigated the performance of various thicknesses of FireMaster Marine Plus Blanket also using guidance given in Table 5 of Section 9.1 of ISO 15665:2001 I. The tested systems and their performance are summarised in Tables 1 to 3.



Typical test arrangement of pipes tested insulated with the FireMaster pipe fire protection system

Measured Dynamic Stiffness Values (EN 29052-1)

FireMaster Marine Plus Blanket,
128 kg/m³

Thickness, mm	Dynamic Stiffness	
	s' (MN/m ³)	SD
25mm	13	SD 14
38mm	11	SD 11
50mm	7	SD 8

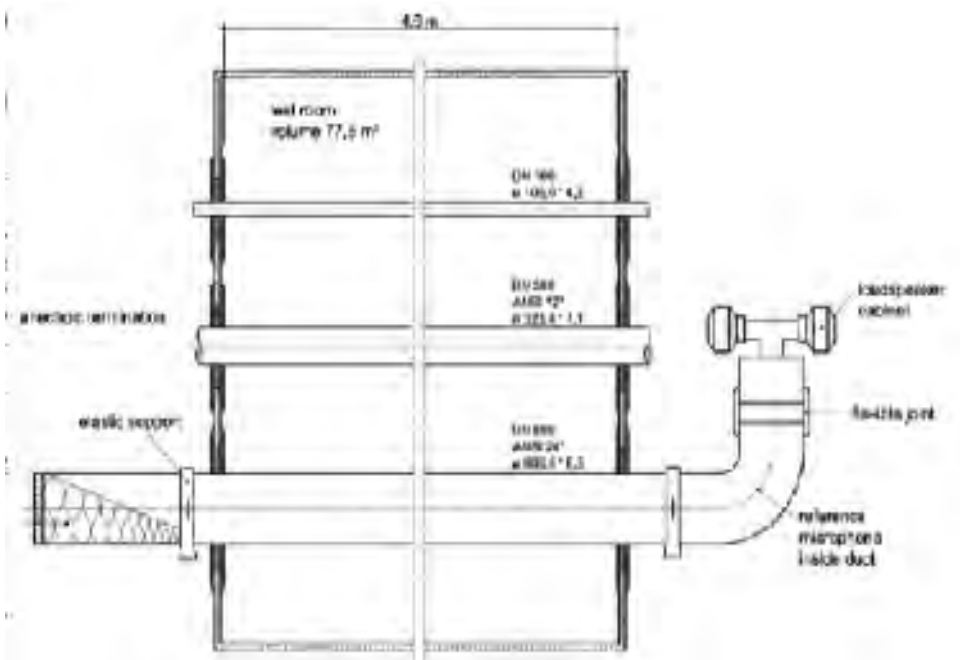

Schematic of the test arrangement used to measure insertion loss to ISO 15665:2003 method.

Acoustic insulation properties of FireMaster® pipe fire protection system

Table I:
Third Octave band Insertion Loss (dB) of FireMaster Marine Plus Blanket pipe insulation system
measured in accordance with ISO 15665.

Insulation System	Pipe	Frequency, Hz							
		63	125	250	500	1000	2000	4000	8000
FireMaster Marine Plus Blanket 50mm + 0.6mm steel cladding	DN 100	-8	-12	-6	1	13	20	23	32
	DN 300	-5	-6	-7	3	13	25	29	41
	DN 600	-4	-4	-5	3	11	21	35	44
FireMaster Marine Plus Blanket 50 mm + 1mm steel cladding	DN 100	2	-3	1	6	11	12	27	36
	DN 300	-2	-6	-5	1	8	20	26	39
	DN 600	-2	-4	-5	2	10	19	33	42
FireMaster Marine Plus Blanket 75mm + 0.8mm steel cladding	DN 100	3	0	-6	4	10	21	33	42
	DN 300	-7	-16	-4	2	13	26	31	36
	DN 600	-6	-9	-2	5	20	30	42	37
FireMaster Marine Plus Blanket 100mm + 0.6mm steel cladding	DN 100	-10	-16	-7	5	13	21	28	33
	DN 300	-7	-7	-1	5	15	26	32	50
	DN 600	-9	-14	0	13	27	33	46	47
FireMaster Marine Plus Blanket 100mm + 1.0mm steel cladding	DN 100	1	-1	0	11	26	35	44	43
FireMaster Marine Plus Blanket 100mm + 1.3mm steel cladding	DN 300	-6	-3	7	14	28	39	44	42
	DN 600	-5	-4	5	19	32	40	45	44

Table 2:

Third octave Band Insertion Loss (dB) measured for FireMaster® Marine Plus Blanket 128 kg/m³ and anti-drumming compound applied on pipes

Insulation System	Pipe	Frequency, Hz							
		63	125	250	500	1000	2000	4000	8000
FireMaster Marine Plus Blanket 50mm + 0.6mm steel cladding	DN 100	-8	-12	-6	1	13	20	23	32
FireMaster Marine Plus Blanket 50mm + 0.6mm steel cladding + 3mm anti-drumming compound		-5	-4	-4	3	12	27	33	35
FireMaster Marine Plus Blanket 75 mm + 0.8 mm steel cladding	DN 300	-7	-16	-4	2	13	26	31	36
FireMaster Marine Plus Blanket 75 mm + 0.8 mm steel cladding + 3mm anti-drumming compound		-8	-7	-2	5	16	31	37	32
FireMaster Marine Plus Blanket 75 mm + 0.8 mm steel cladding	DN 600	-6	-9	-2	5	20	30	42	37
FireMaster Marine Plus Blanket 75 mm + 0.8 mm steel cladding + 3mm anti-drumming compound		-4	-9	-1	8	25	35	44	39

Acoustic insulation properties of FireMaster® pipe fire protection system

Table 3:
Third octave Band Insertion Loss (dB) measured for FireMaster Marine Plus Blanket 128 kg/m³
with and without cladding applied on pipes

Pipe	System	Frequency, Hz							
		63	125	250	500	1000	2000	4000	8000
DN 600	50mm no cladding	-1	-5	-6	3	12	23	35	32
	50mm + 0.6mm steel cladding	-4	-4	-5	3	11	21	35	44
	50mm + 1mm cladding	-2	-4	-5	2	10	19	33	42

Important note on testing result values
Frequencies of 63dB and 125db are below the lower frequency range of the test room used according to ISO 3741. The measured insertion loss values in the tables have been increased by 3dB accordingly as specified in the test report.

The frequency of 250dB is close to the frequency limit for the test room and the measured insertion loss values in the tables have been increased by 1dB from the measured results, again as specified in the test report.

Sound Transmission Classes ISO 15665:2011

The minimum insertion loss required to meet each class is given for reference only. In referencing these classes, the following information should be considered.

1. The primary purpose of FireMaster® Marine Plus Blanket is to provide fire insulation and not to meet a specific sound transmission classification.
2. In order to provide jet fire protection, the choice of cladding material required to meet fire protection requirements may not be optimal for acoustic insulation.
3. When designing fire protection systems, thickness of insulation varies according to critical pipe temperature rise limits (with varying operating temperatures) and pipe section factor. It may not be possible to comply with sound insulation class limits in all octave bands when considering only fire thermal insulation requirements; i.e. the insulation or cladding thickness may need to be increased to meet insertion loss requirements.
4. The spectral class limits defined in ISO 15665:2011 are specified for general pipe assemblies not taking into account the specific composition of the actual sound emissions for operating process. For example, for high frequency noise from gas pipes the insertion loss values at low frequencies could be of negligible importance. It may not be necessary to meet insertion loss limits for all frequency points and therefore optimisation of the insulation system for fire insulation may be possible. For this reason, a large variety of insertion loss tests have been carried out on the FireMaster system with varying insulation and cladding thicknesses.

Class	Pipe Min Diameter, mm	Pipe Max Diameter, mm	Frequency, Hz						
			125	250	500	1000	2000	4000	8000
A1		<300	-4	-4	2	9	16	22	29
A2	≥300	<650	-4	-4	2	9	16	22	29
A3	≥650	<1000	-4	2	7	13	19	24	30
B1		<300	-9	-3	3	11	19	27	35
B2	≥300	<650	-9	-3	6	15	24	33	42
B3	≥650	<1000	-7	2	11	20	29	36	42
C1		<300	-5	-1	11	23	34	38	42
C2	≥300	<650	-7	4	14	24	34	38	42
C3	≥650	<1000	-1	9	17	26	34	38	42



The background of the slide features architectural drawings. The top half shows a cross-section of a building facade with a dome-like structure on the left and various wall and window profiles on the right. The bottom half shows a floor plan with a central circular area containing a spiral staircase, surrounded by rectangular rooms and corridors. Numerous numerical callouts are scattered throughout the drawings, such as 17050, 18970, 18490, 17690, 16770, 15640, 8160, 7760, 7700, 6950, 850, 3230, 7890, 7050, 6270, 5810, 5180, 4788, 3620, 3200, 1040, 8670, R14, R16, R22, R215, 2500, 8750, 8886, 2500, 100, 1040, 7700, 6950, 6750, 430, 720, 8160, 7760, 7700, 6950, 850, 8750, 8886, 2500, 1040, 100, 130, 17050, 18970, 18490, 17690, 16770, 15640, 8160, 7760, 7700, 6950, 850, 3230, 7890, 7050, 6270, 5810, 5180, 4788, 3620, 3200, 1040, 8670, R14, R16, R22, R215, 2500, 8750, 8886, 2500, 100, 1040, 7700, 6950, 6750, 430, 720, 8160, 7760, 7700, 6950, 850, 8750, 8886, 2500, 1040, 100, 130.

FireMaster[®] Rigid Enclosure System (RES)

FireMaster® Rigid Enclosure System

FireMaster RES - Rigid Enclosure System

The FireMaster Rigid Enclosure System consists of a stainless steel enclosure incorporating our high performance FireMaster

It is fire tested for jet fire protection of valves, actuators and pipe flanges to ISO 22899-1 standard for up to 60 minutes. Very low critical temperature items can be insulated due to the high performance insulation used in the enclosure.

The FireMaster RES is custom-manufactured in sections designed to fit around the item requiring protection and can incorporate water drain and inspection hatch features if required.



- Easy fitting and removal is ensured through a simple clip fixing system with fire sealing materials incorporated into the shells.

- The robust stainless steel casing is especially suitable for use in weather-exposed areas.

- The system has been demonstrated to have blast resistance to 0.5 bar overpressure. See page 65 for details.

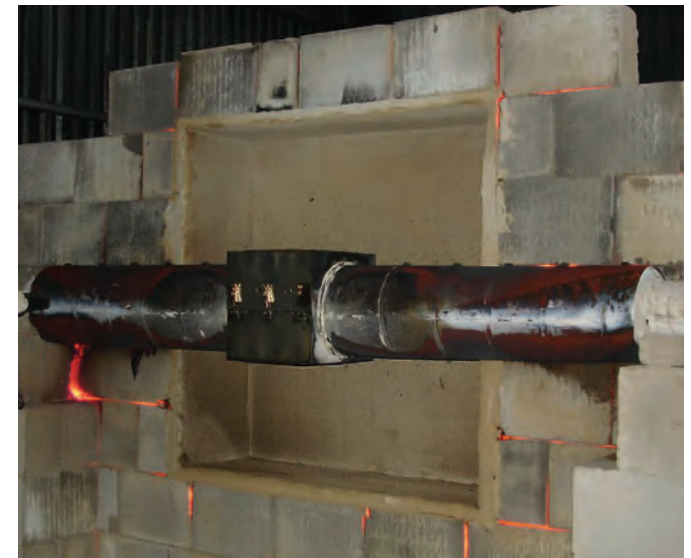

FireMaster® Rigid Enclosure System

FireMaster® RES - Rigid Enclosure System

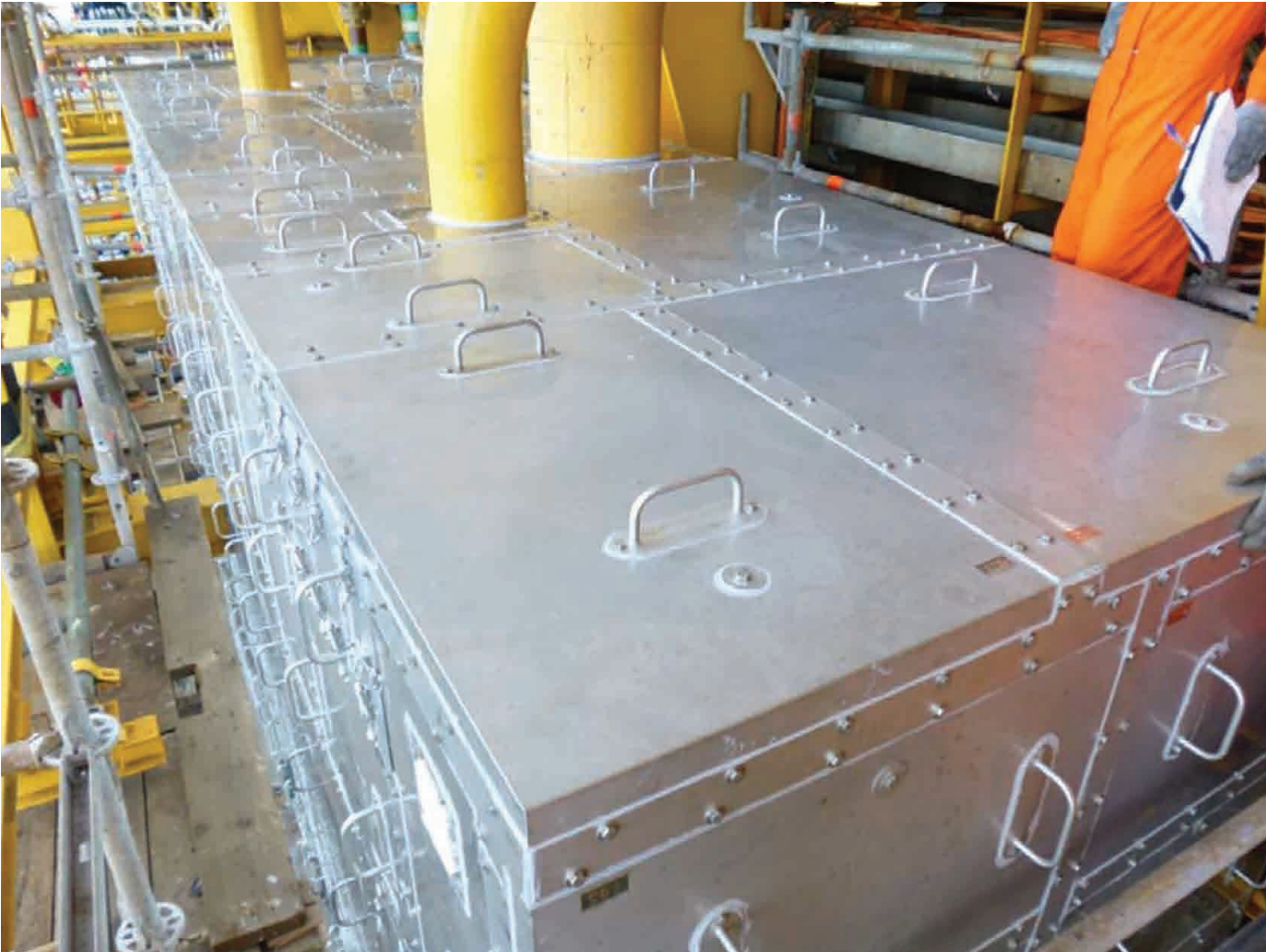

Fire protection for process equipment



For large units requiring fire protection, the RES System is installed as panels onto a supporting framework. Example shown in these photographs is a skid unit for actuators for 50 minute jet fire protection. Exterior unit dimensions were 4m long x 2.2m deep x 2.8m high. Access doors can be incorporated into the panel system.

FireMaster® Rigid Enclosure System

FireMaster RES - Rigid Enclosure System. Explosion resistance to 0.5 bar

a	Pipe. The RES system is installed over the applied pipe fire insulation system where fire insulation is fitted.
b	Integral collar incorporating insulation.
c	Valve.
d	Internal lightweight stainless steel casing.
e	316 stainless steel outer casing.

Rigid Enclosed System - system I, showing stainless steel outer casing

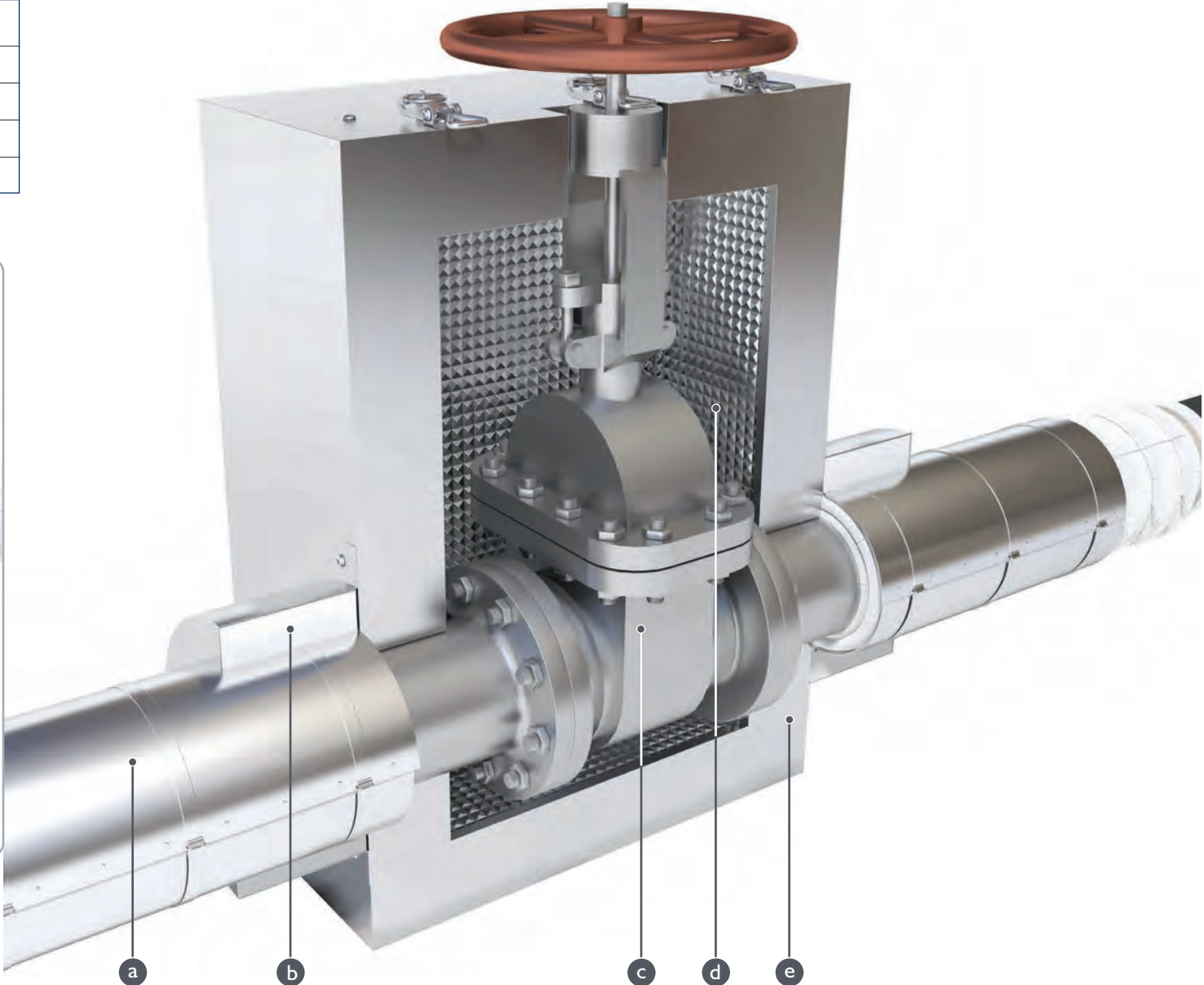
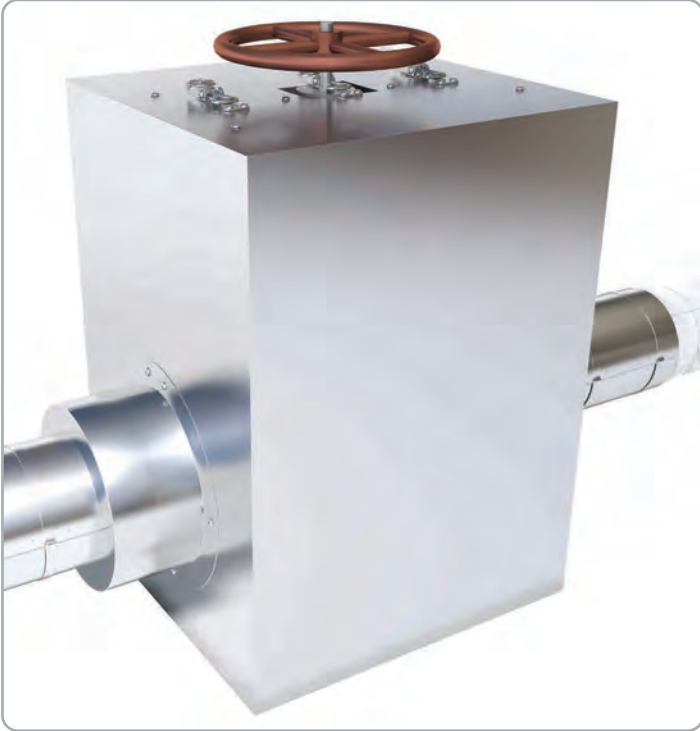

FireMaster® RES - Rigid Enclosure System

a	Pipe. The RES system is installed over the applied pipe fire insulation system where fire insulation is fitted.
b	Internal lightweight stainless steel casing.
c	Flange unit.
d	Retention clips for RES casing.
e	Collar attachment for pipe incorporating insulation.

Rigid Enclosed System - system 2,
showing stainless steel outer casing

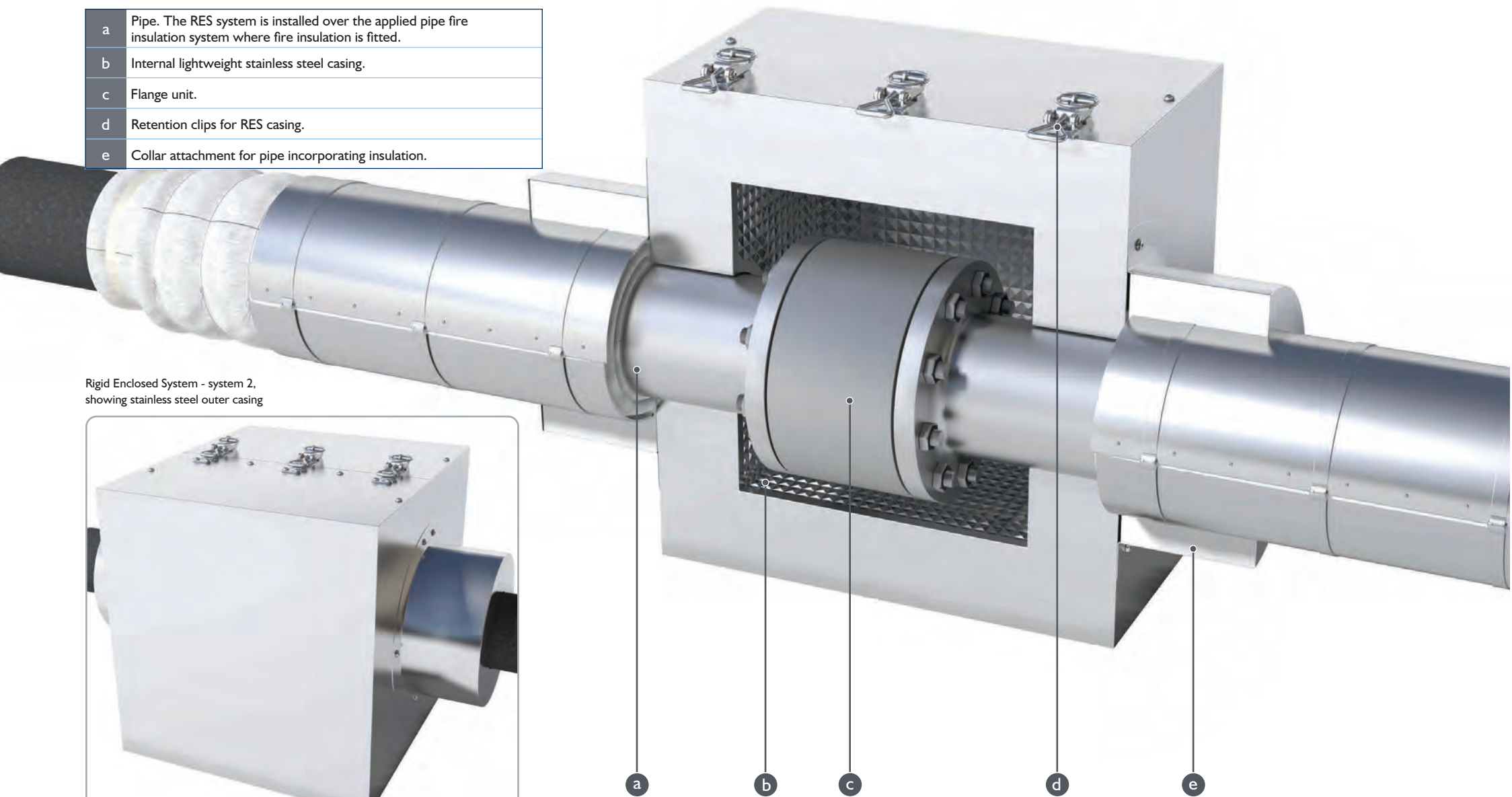

FireMaster® Rigid Enclosure System

FireMaster RES - Rigid Enclosure System - flange fire protection

Rigid Enclosed System - flange fire protection

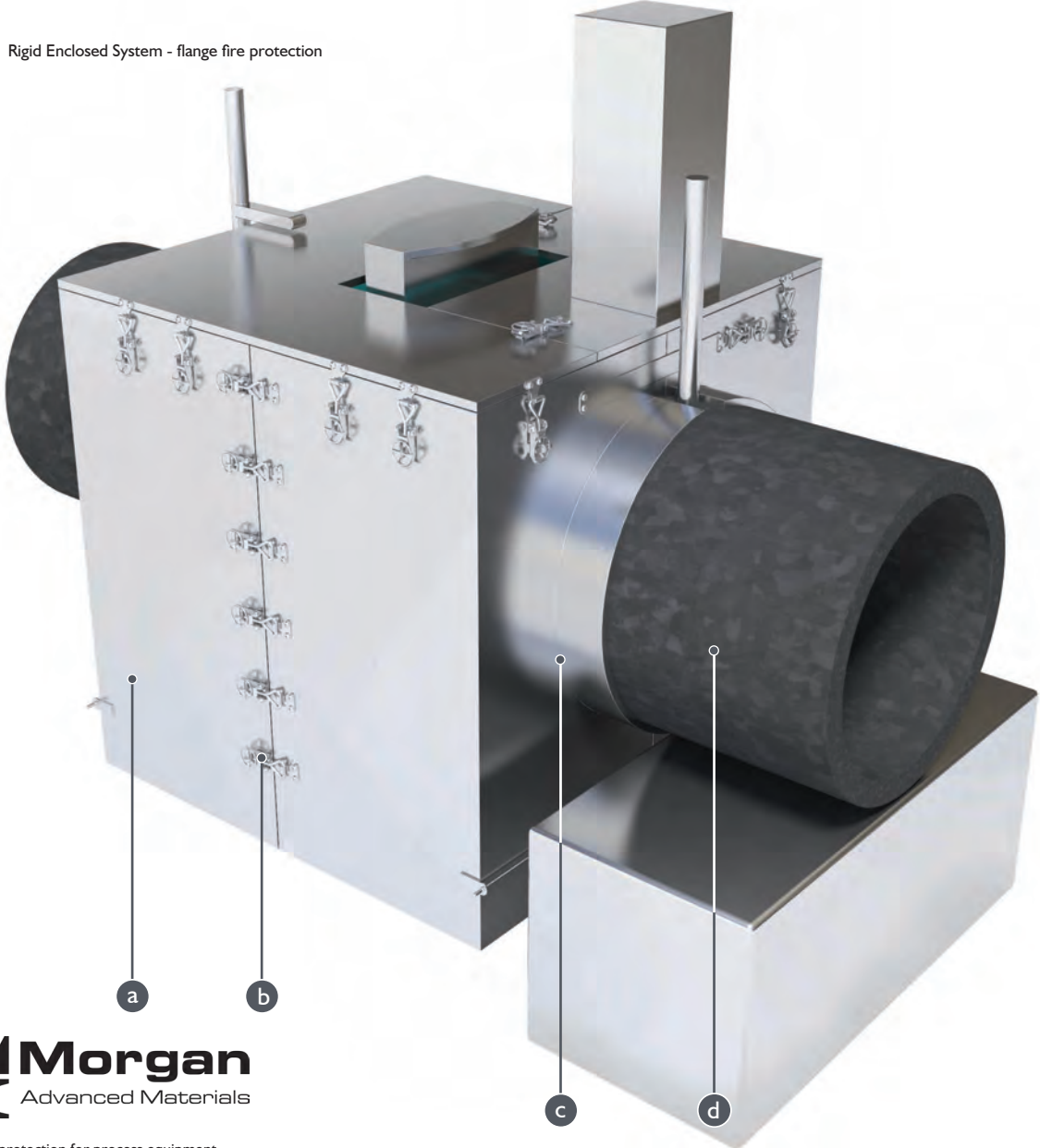

a	316 stainless steel outer casing.
b	Retention clips for RES casing.
c	Integral collar incorporating insulation.
d	Pipe. The RES system is installed over the applied pipe fire insulation system where fire insulation is fitted.

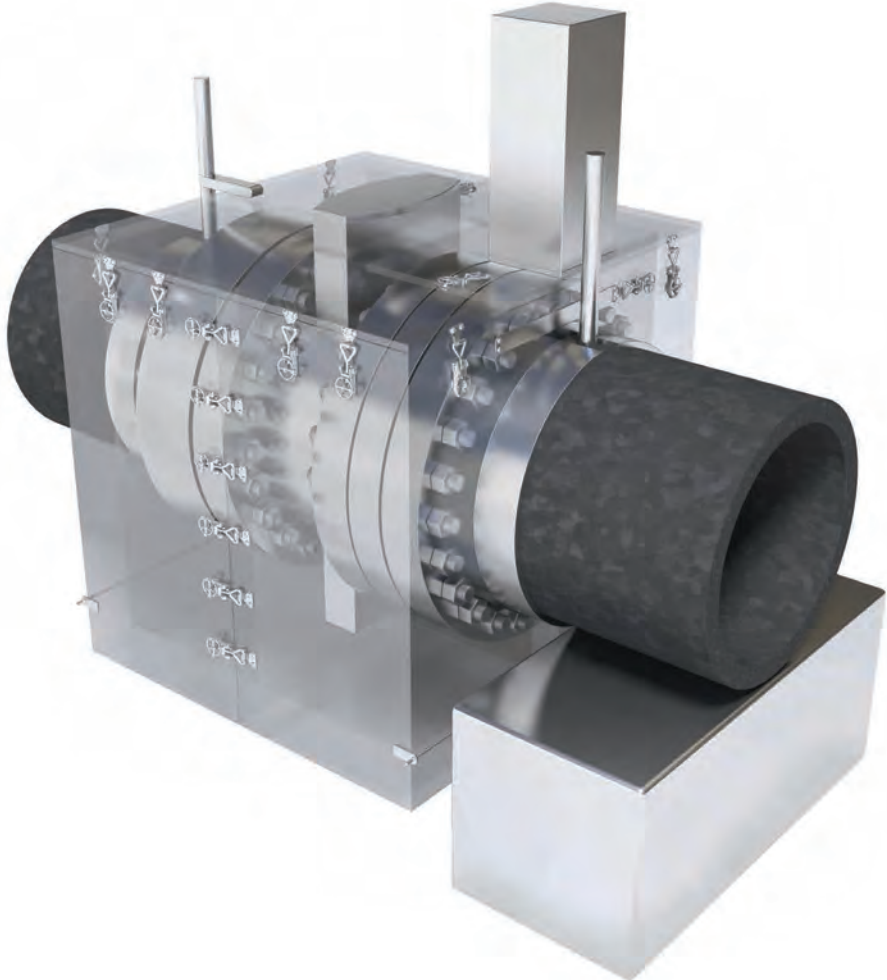

Valve and actuator fire protection

Commonly used standards for the specification or the fire testing of passive fire protection systems are usually based on ensuring the critical temperatures of structural elements such as steelwork or fire walls are not exceeded. Whereas structural steel sections may have a critical temperature of typically 400°C, the critical temperature limits of processing equipment such as valves or actuators or flanges is often much lower; for example less than 150°C.

It is therefore advisable to ensure that systems offered for the fire protection of such critical components are independently tested and approved to provide adequate protection, i.e. that they ensure the specified critical temperature of the component will not be exceeded. In addition, all components (fixings, sealants etc) of the assembly as fitted on site should also have been demonstrated to be suitable through relevant fire testing. Where enclosures are used that are different in size to those that have been fire tested, their design (e.g. joint type and locations) should be authorized within a Type Approval.

A fire test on an enclosure system demonstrates both the integrity of the enclosure and its insulation capability. Careful consideration must be made of the limitations of size or mass of the contents of the enclosure as tested, as changes to the fire insulation fitted into each enclosure may be required for contents that have a lower critical temperature or less heat capacity. In such cases, certification for the enclosure system may place a maximum limit of the surface area to mass relationship (or 'section factor') of the contents or alternatively encompass an approved method for changing the insulation specification to suit contents with varying mass, section factors or critical temperatures.

FireMaster® RES independent fire test results and Type Approval

Two alternative designs of the FireMaster® RES passive fire protection system have been fire tested incorporating inspection hatches, drain plug and alternative insulation designs.

The tests utilise the RES system as protection for a tubular steel specimen with a central steel section constructed to represent the body of a valve or actuator of maximum section factor 80m⁻¹ protected by the enclosure.

60-minute duration

The RES enclosure has been fire tested in 2 impinging jet fires tests witnessed by Lloyds Register and carried out at DNV-GL, Spadeadam, UK in accordance with the ISO 22899-1 test method for tubular specimens.

FireMaster RES has Lloyds Register Type Approval as follows
Maximum Section Factor of item to be protected: 80m⁻¹

Insulation System 1

JF/Pipe System Components/125/60

JF/Pipe System Components/75/45

JF/Pipe System Components/35/30

Insulation System 2

JF/Pipe System Components/220/60

JF/Pipe System Components/130/45

JF/Pipe System Components/50/30

Explosion Resistance

The RES system has been tested at DNV-GL Spadeadam laboratory for resistance to gas explosion overpressure to 0.5 bar. See page 65 for details.



FireMaster[®] Flexible Enclosure System (FES)



FIRE PROTECTION

FireMaster® Flexible Enclosure System (FES)

Jet fire protection - for vulnerable equipment with low critical temperature limits

The FireMaster Enclosure system is specifically designed to provide high performance jet fire protection, especially for vulnerable equipment with low critical

Flexible systems are lighter in weight than rigid enclosures and typically used where regulations do not require metallic enclosures to be fitted but an easily removable system is still desired.



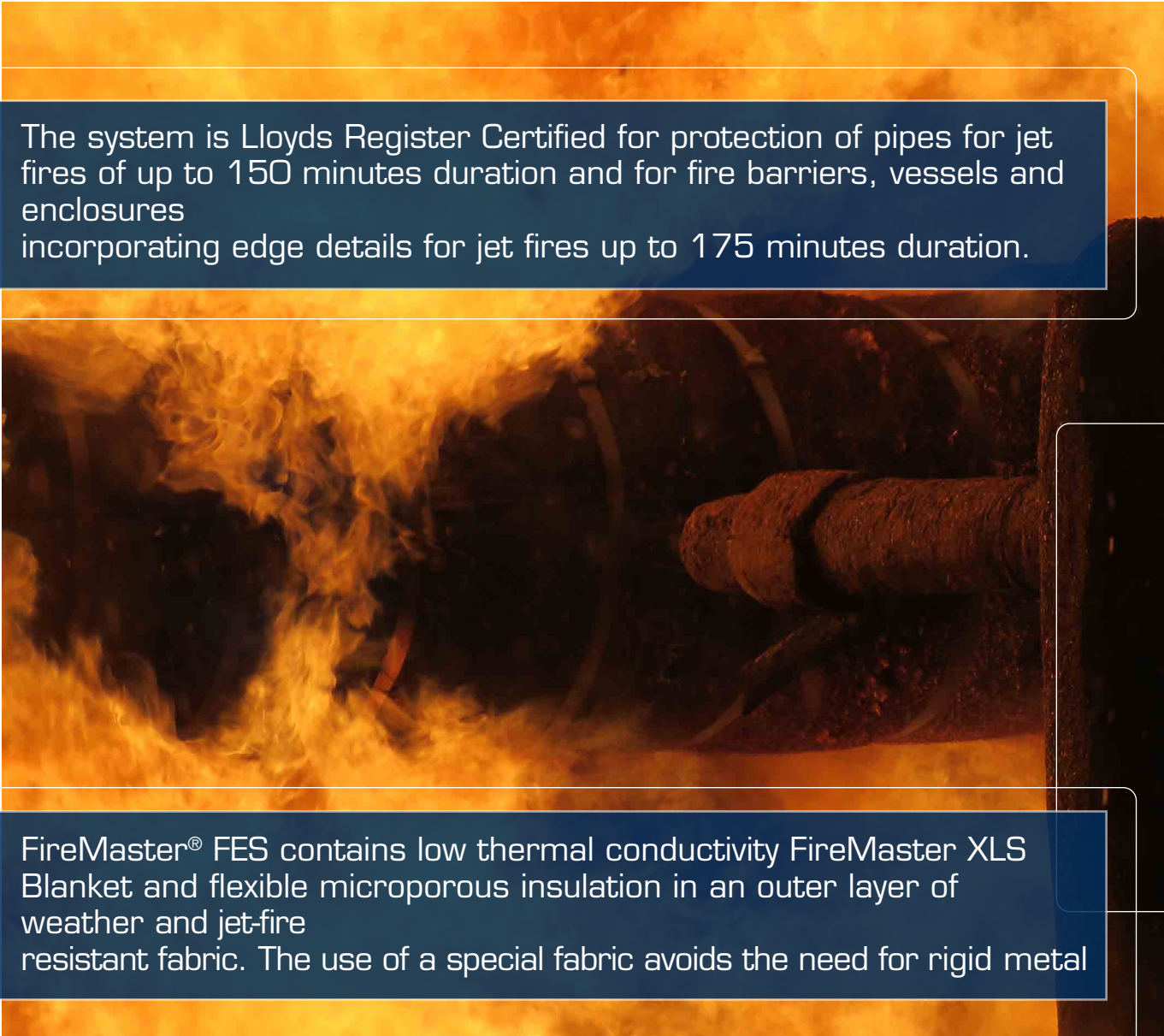

The system is Lloyds Register Certified for protection of pipes for jet fires of up to 150 minutes duration and for fire barriers, vessels and enclosures incorporating edge details for jet fires up to 175 minutes duration.

FireMaster® FES contains low thermal conductivity FireMaster XLS Blanket and flexible microporous insulation in an outer layer of weather and jet-fire resistant fabric. The use of a special fabric avoids the need for rigid metal



FireMaster® Flexible Enclosure System (FES)

Jet fire protection - for vulnerable equipment with low critical temperature limits

FireMaster Flexible Enclosure System (FES) - Pipes

Jacket thickness is 70mm (2 x 25mm of FireMaster XLS and 2 x 10mm of microporous insulation). Outer cloth facing the jet fire is different from the inner cloth. The outer is jet fire resistant and the inner is only weather resistant.

The jacket is held in place with banding straps and lacing and there is an overlap at the joint. See additional data.

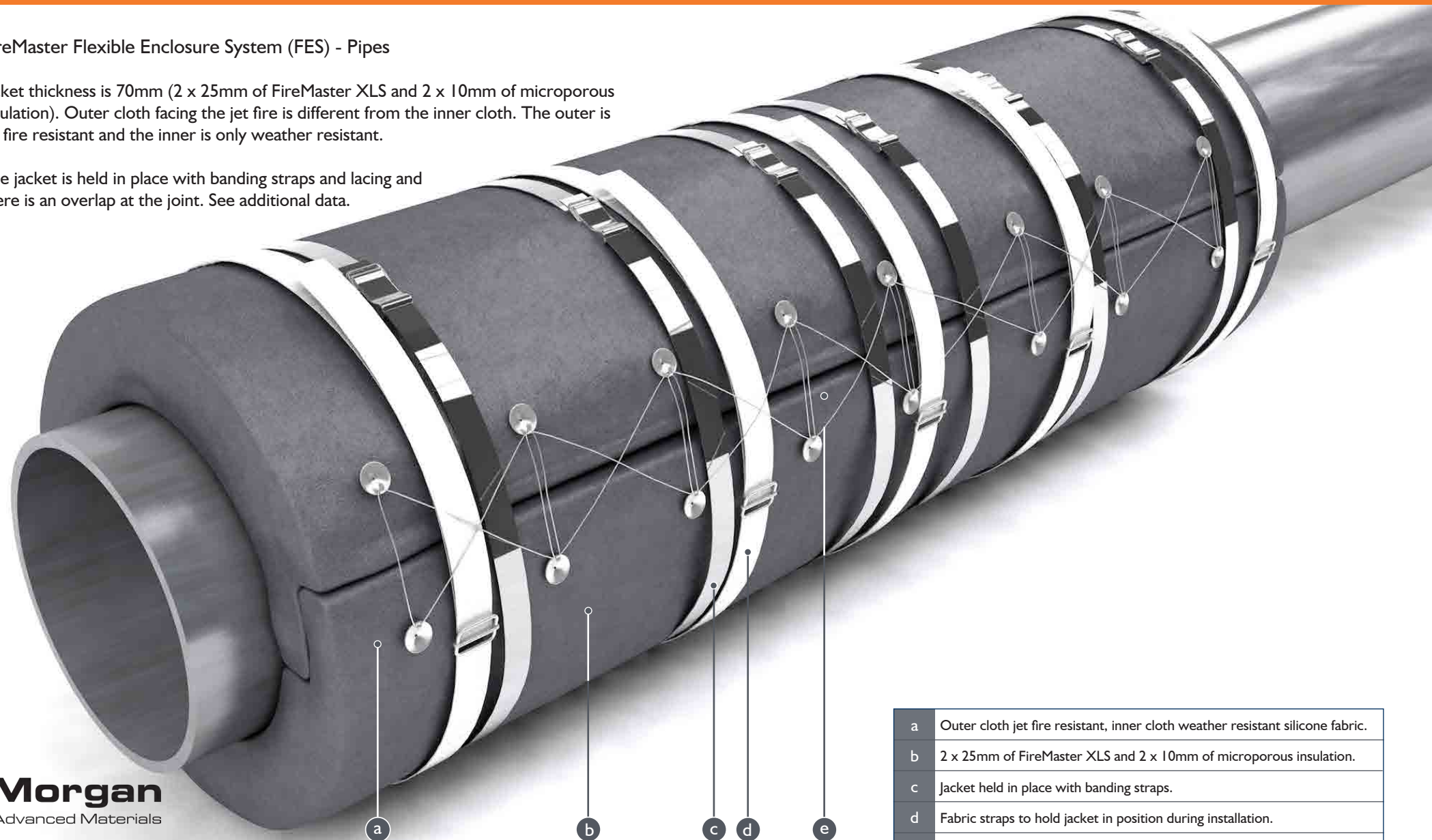

a	Outer cloth jet fire resistant, inner cloth weather resistant silicone fabric.
b	2 x 25mm of FireMaster XLS and 2 x 10mm of microporous insulation.
c	Jacket held in place with banding straps.
d	Fabric straps to hold jacket in position during installation.
e	Wire lacing to hold jacket in place.

FireMaster® Flexible Enclosure System (FES) - detail view

a	Retention clips.
b	Stainless steel wire.
c	Textile band used to facilitate fitting the FES to pipes.
d	Stainless steel banding strap.
e	FES jacket.

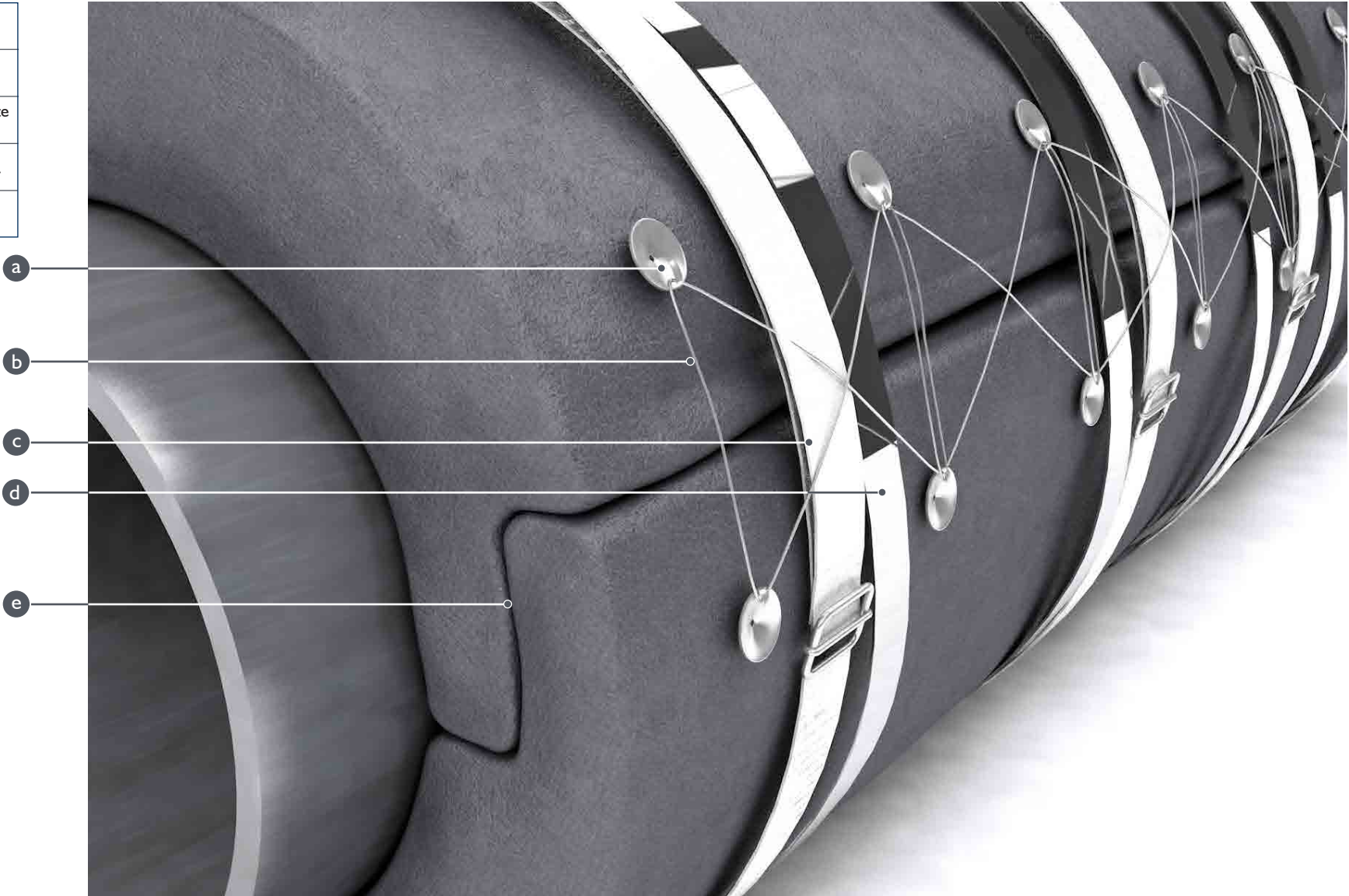

FireMaster® Flexible Enclosure System (FES)

Jet fire protection - for vulnerable equipment with low critical temperature limits

FireMaster Flexible Enclosure System (FES) - Firebarriers and Vessels

The system make up is the same as detailed in the Pipe section on pages 43 and 44 except there is no overlap of the jacket at the edge joint. Instead the outer cloth layer is extended out from the jacket edge and just fits over the joint (i.e. no insulation overlap - only the textile).

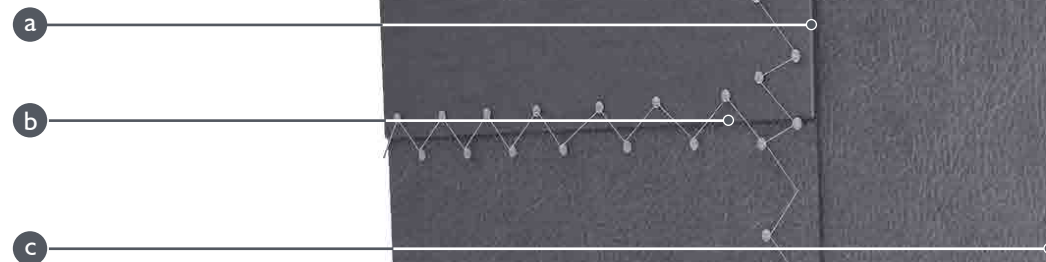

a - b	The FES jacket system is installed with butted joints. The edge of each section of the FES has a 70mm extension of the outer textile which is used to cover the butted joint between jackets. The joints are then laced into place with stainless steel wire and clips.
c	FES Jacket.

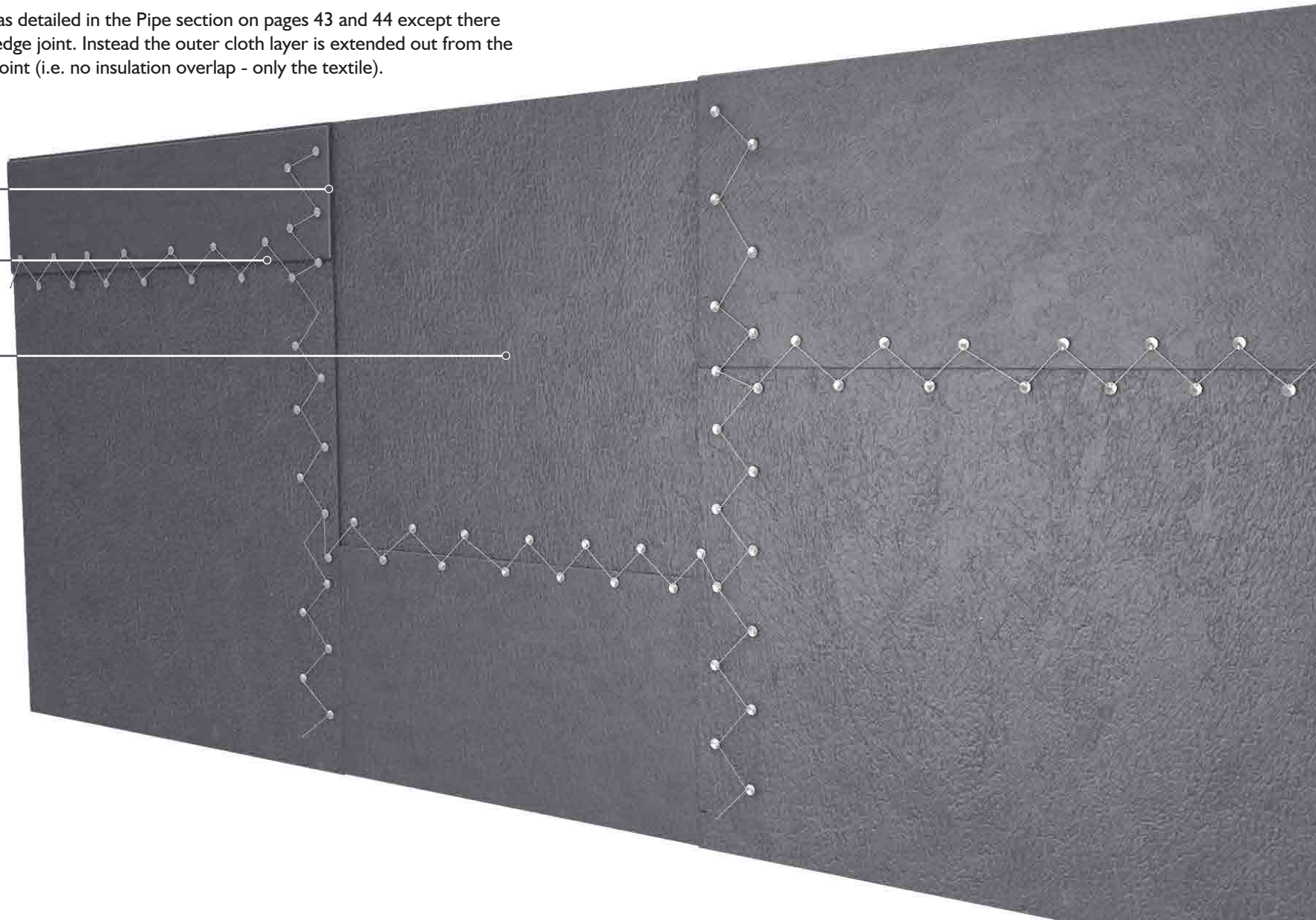

FireMaster® Flexible Enclosure System (FES)

FireMaster Flexible Enclosure System (FES) - Enclosures

The use of these type of systems for enclosures (i.e. where the RES would also be used and anything with an “edge”) requires fire test evidence to prove the edge can withstand the impact of the jet flame. The standard way of doing this is to incorporate a raised section in a wall test simulating the edges of a box. You can see the details of this in the wall test sample, page 48.

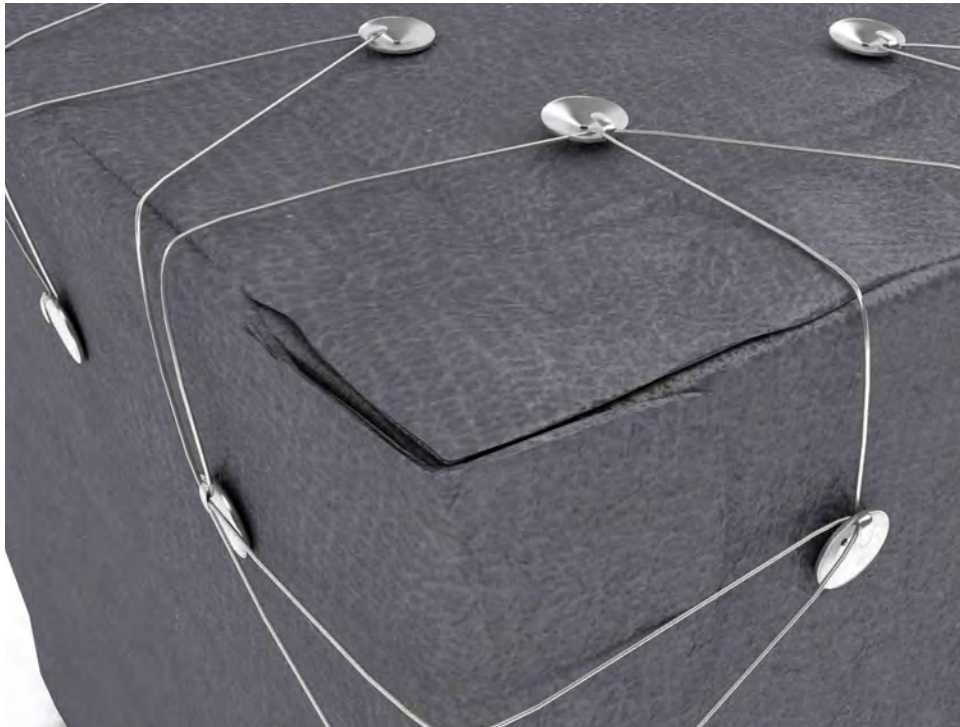
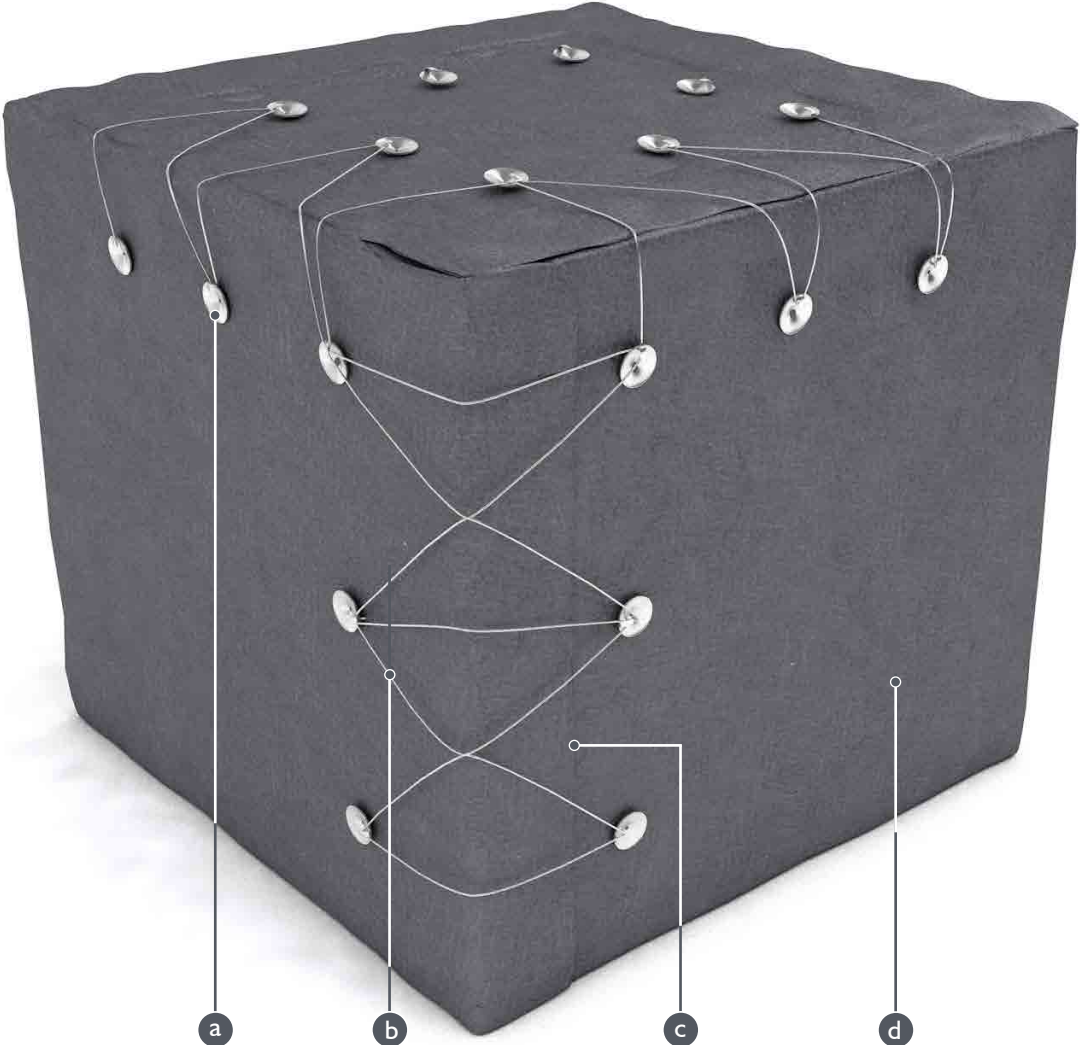

a	Stainless steel fixing clips.
b	Stainless steel wire.
c	Overlap of joints. The FES jackets is manufactured with a 70mm extension of the outer textile at the edge. The edge of each jacket is butted together to fit and the 70mm textile extension covers the joint. The joints are held in place with stainless steel tie wire.
d	FES jacket.

Fire test performance of FireMaster[®] Flexible Enclosure System

The certification issued by Lloyds Register for the FireMaster FES allows its use for jet fire protection applications on “pipework, pressure vessels, valves with flat panels with or without corners and edges”.

The fire testing of the system was specially designed to ensure the suitability of the system for use as an enclosure system could be adequately demonstrated. When flexible jackets are installed on any item with an edge detail, there is a risk that the outer edge may not resist the erosive effect from the jet flame. In order to prove the FireMaster FES could withstand such conditions, a test specimen incorporating a raised section was exposed to a jet fire test of 175 minute duration. Additional thermocouples were installed on the corner sections and the rear panel area behind the raised section to demonstrate the thermal insulation performance of the system.



Raised corner detail used in jet fire test specimen

FireMaster FES system Classification according to ISO 22899-1 / ISO 22899-2

Tubular Sections (max. section factor 128m ⁻¹)	Fire Barriers and Pressure Vessels
JF/Tubular Section/23/15	JF/Fire Barrier or Pressure Vessels/25/15
JF/Tubular Section/64/30	JF/Fire Barrier or Pressure Vessels/53/30
JF/Tubular Section/146/60	JF/Fire Barrier or Pressure Vessels/111/60
JF/Tubular Section/224/90	JF/Fire Barrier or Pressure Vessels/165/90
JF/Tubular Section/309/120	JF/Fire Barrier or Pressure Vessels/224/120
JF/Tubular Section/400/150	JF/Fire Barrier or Pressure Vessels/262/150
	JF/Fire Barrier or Pressure Vessels/272/165
	JF/Fire Barrier or Pressure Vessels/277/175



FireMaster[®] Instrument cable tray fire protection

Instrument cable tray fire protection

30 minute hydrocarbon fire protection

FireMaster® products insulate cable trays carrying instrument control cables to ensure that the cables can operate long enough to allow process shut down during fires.

The FireMaster Cable Tray Wrap System provides 30 minutes hydrocarbon fire protection to cable trays carrying control cable wiring.

The FireMaster Cable Tray Wrap consists of FireMaster Marine Plus Blanket fully encapsulated in aluminium foil supplied and in a roll form. It is wrapped around the exterior of the cable tray and held in place with steel banding straps. Additional weather protection can



- The FireMaster® Cable Tray Wrap System has been installed in many chemical process plants world-wide and is fire tested to the stringent ASTM E1725

- It can be installed in one single layer which means installation time is quick and the wrap can be easily removed from the cable tray if retrofitting of cables is required.



Instrument cable tray fire protection

30 minute hydrocarbon fire protection

a	Cable tray containing instrument control cables.
b	Banding strap at 150mm centres used to support mesh lining on top of open trays.
c	Mesh lining used to prevent cable tray wrap from slumping on top of tray.
d	Stainless steel banding straps minimum 12mm wide installed at 40mm from the edge of each cable tray wrap piece with one strap placed in the centre. If 1220mm wide cable tray wrap is being installed, use a maximum spacing of 250mm between the band straps. The bands must be tightened so as to securely hold the cable tray wrap to the tray, but not so tight as to cut it.
e	FireMaster® Cable Tray Wrap 50mm thick supplied in widths of 610mm or 1220mm. Installed in one layer with overlapped joints of 75mm. Additional bands may be placed as needed such as at elbows and 90 degree bends to assure tight joints.
f	Overlap of 75mm between adjacent cable tray wrap pieces.

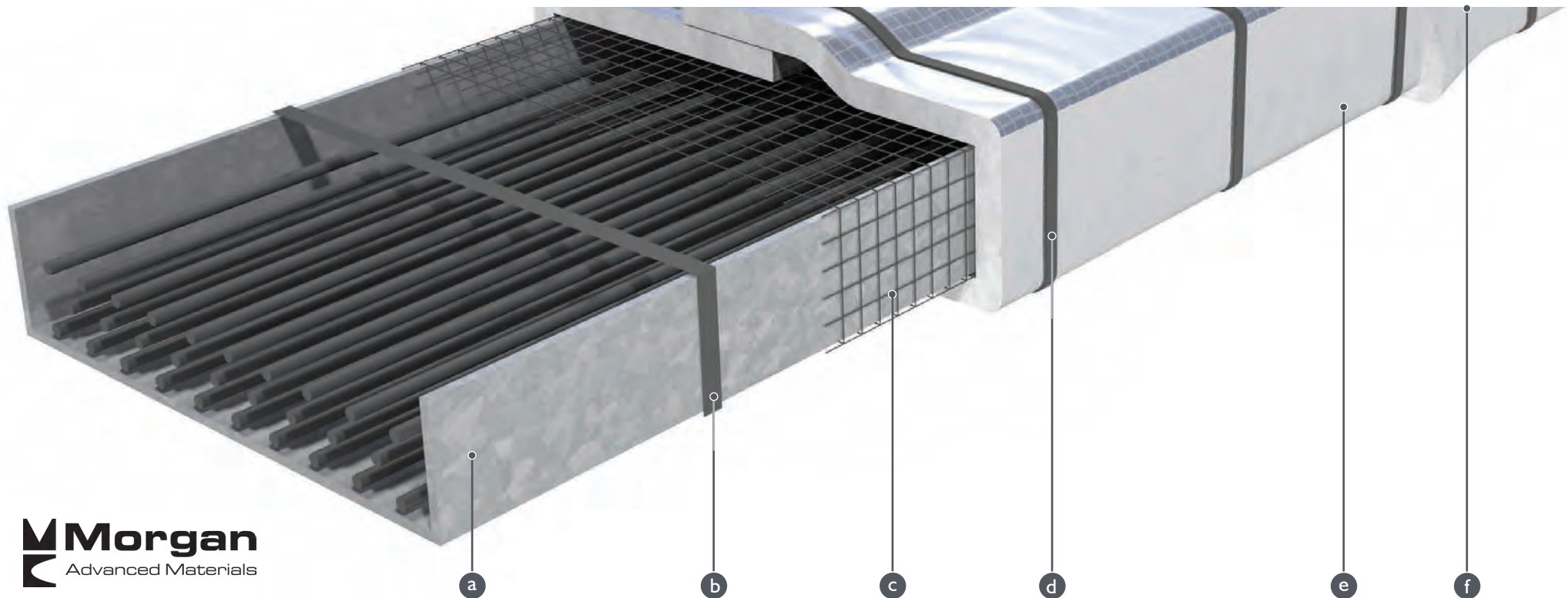

Instrument cable tray fire protection with optional weather proofing system

a	Cable tray containing instrument control cables.
b	Banding strap at 150mm centres used to support mesh lining on top of open trays.
c	Mesh lining used to prevent cable tray wrap from slumping on top of tray.
d	Stainless steel banding straps minimum 12mm wide installed at 40mm from the edge of each cable tray wrap piece with one strap placed in the centre. If 1220mm wide cable tray wrap is being installed, use a maximum spacing of 250mm between the band straps. The bands must be tightened so as to securely hold the cable tray wrap to the tray, but not so tight as to cut it.
e	FireMaster® Cable Tray Wrap 50mm thick supplied in widths of 610mm or 1220mm. Installed in one layer with overlapped joints of 75mm.
f	Corrugated aluminium sheeting 0.6mm thick for weather protection.

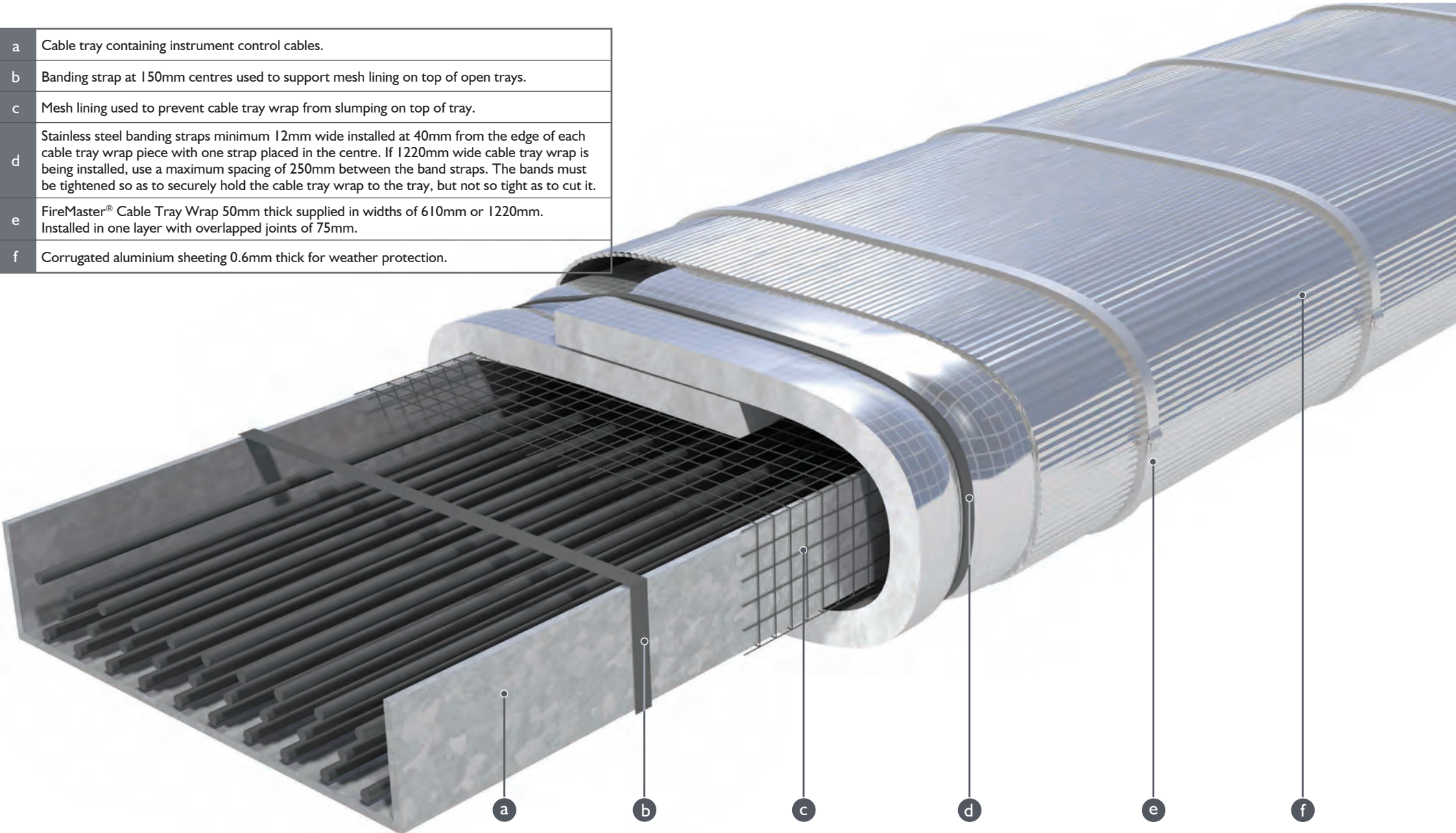

Cable tray fire protection fire testing and certification

Instrument cable tray fire protection has several purposes. These are:

- Maintain cable function in a fire
- Prevent corrosive/toxic gas emission when cable burns
- Protect fire fighters
- Aid evacuation
- Minimise long-term damage to cable facilities

ASTM E1725-95 'Standard Test Methods for Fire Tests of Fire Resistive Barrier Systems for Electrical System Components' is designed to measure and describe the response of electrical system materials, products or assemblies to heat or flame under controlled conditions. This test can be carried out using either cellulosic or hydrocarbon fire curves (ASTM E119 and E1529 respectively).

API 2218 'Fire Proofing Practices in Petroleum and Petrochemical Processing Plants' references ASTM E1725-95 test method and states that for applicability to petroleum and petrochemical processing plants, the fire test should be carried out using a hydrocarbon fire temperature/time curve.

API 2218 considers the ASTM E1529 and UL 1709 hydrocarbon fire curves to be functionally equivalent. These fire curves are similar. The ASTM E1529 curve is slightly higher in temperature than UL 1709 and specifies a heat flux taken from measurements of hydrocarbon pool fires (see Appendix I of ASTM E1529 for further information).

The two fire curves are shown on the graph opposite.

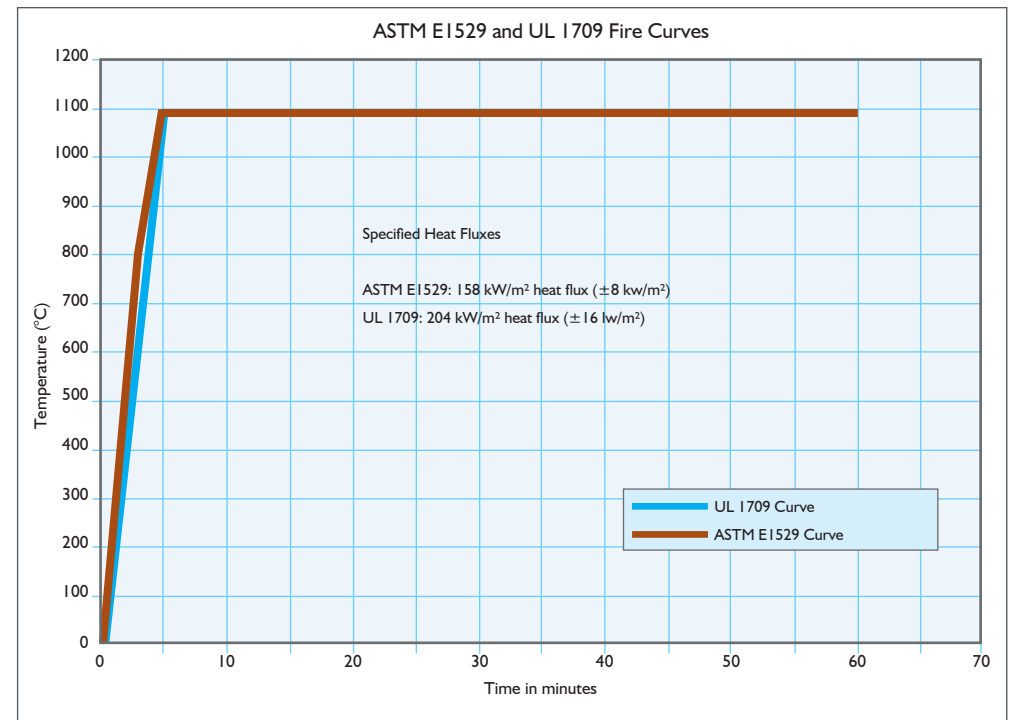

The ASTM E1725-95 test method has stringent requirements for performance of cable tray fire insulation systems. The key features of the test are:

- The test is run at positive pressure over at least ½ the test assembly
- Thermocouples are arranged in sets, fixed into the tray every 150mm on both rails of the cable tray, and every 150mm on a bare copper wire centered in the tray
- The cable tray is intended to be run empty of cables, providing approval for 0% to 100% cable loading
- Failure is determined when one thermocouple 'set' reaches an average temperature rise of 250°F, (121°C) or any single thermocouple reaches 325°F (163°C)

Cable tray fire protection fire testing and certification

Assessing the performance of cable tray fire insulation systems using cable temperature versus circuit integrity

ASTM E1725 uses cable tray temperature as the failure criterion because circuit integrity has been shown to be unreliable as an indicator of failure of a cable.

This is the result of research that indicated cables believed to be of identical composition and rating had different functional failure temperatures.

This means that circuit integrity failure cannot be assumed to reliably occur at the same time point in a fire. Therefore, it is more reliable to establish a maximum temperature beyond which any cable can be considered to be at risk of failure.

Using cable temperature as the failure criterion ensures that the maximum temperature at which functionality of any cable can be assumed to be maintained is not exceeded, even if circuit integrity can be maintained by the sample cable used in the fire test. Furthermore, the measurement of tray rather than cable temperature, with an empty tray, allows any cable loading to be used in practice.

Certification approval

The FireMaster® instrument control cable tray system is Factory Mutual Approved for 30 minute hydrocarbon fire protection of instrument control cable trays in accordance with ASTM E1725-95 method using the ASTM E1529 hydrocarbon fire curve.

The FM Approval is valid for manufacture of FireMaster Cable Tray Wrap at a number of Morgan Advanced Materials factories worldwide.



FireMaster[®] vessel fire protection system



FIRE PROTECTION

FireMaster[®] vessel fire protection system

Hydrocarbon and Jet Fire protection for process vessels

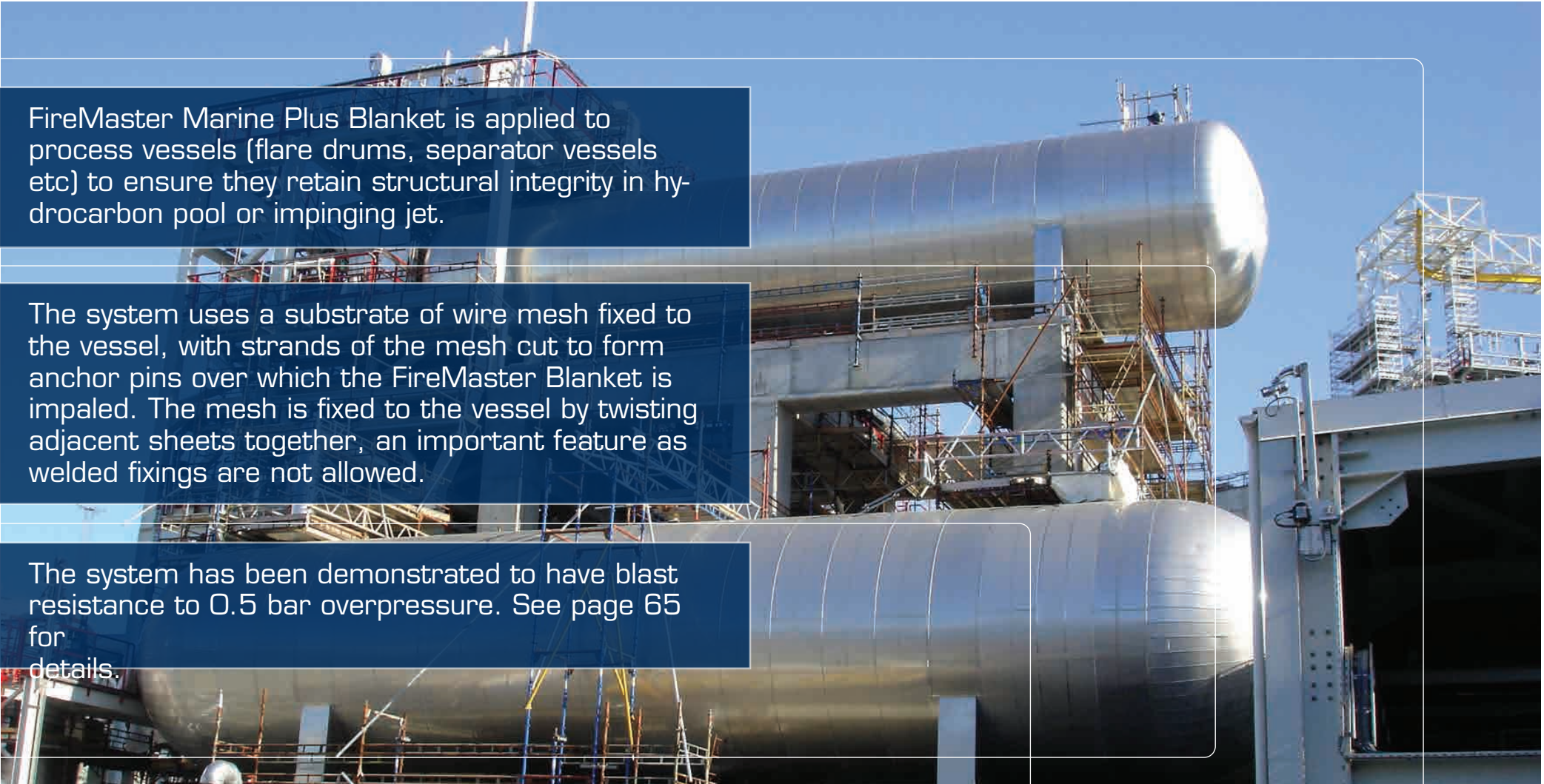

FireMaster Marine Plus Blanket is applied to process vessels (flare drums, separator vessels etc) to ensure they retain structural integrity in hydrocarbon pool or impinging jet.

The system uses a substrate of wire mesh fixed to the vessel, with strands of the mesh cut to form anchor pins over which the FireMaster Blanket is impaled. The mesh is fixed to the vessel by twisting adjacent sheets together, an important feature as welded fixings are not allowed.

The system has been demonstrated to have blast resistance to 0.5 bar overpressure. See page 65 for details.

- Weather-protective cladding is applied over the system using ring supports.

- Fire tested in hydrocarbon pool fires for 3 hours. Fire tested for 190 minutes Jet Fire Protection to ISO 22899-1 standard. JF/Process Vessel/195/180. Blanket also provides thermal insulation for the vessel as well as fire insulation.

- Ideally suited for vessels operating at above-ambient temperatures where heat-reactive fire protection materials cannot be used without secondary insulation being first applied around the vessel.



FireMaster® vessel fire protection system

Hydrocarbon and Jet Fire protection for process vessels

a	Support Ring for exterior cladding.
b	Fixing support for FireMaster Marine Plus fire insulation blanket.
c	FireMaster Marine Plus Blanket with aluminium foil facing.
d	Retaining washers for FireMaster Marine Plus Blanket.
e	Exterior cladding.

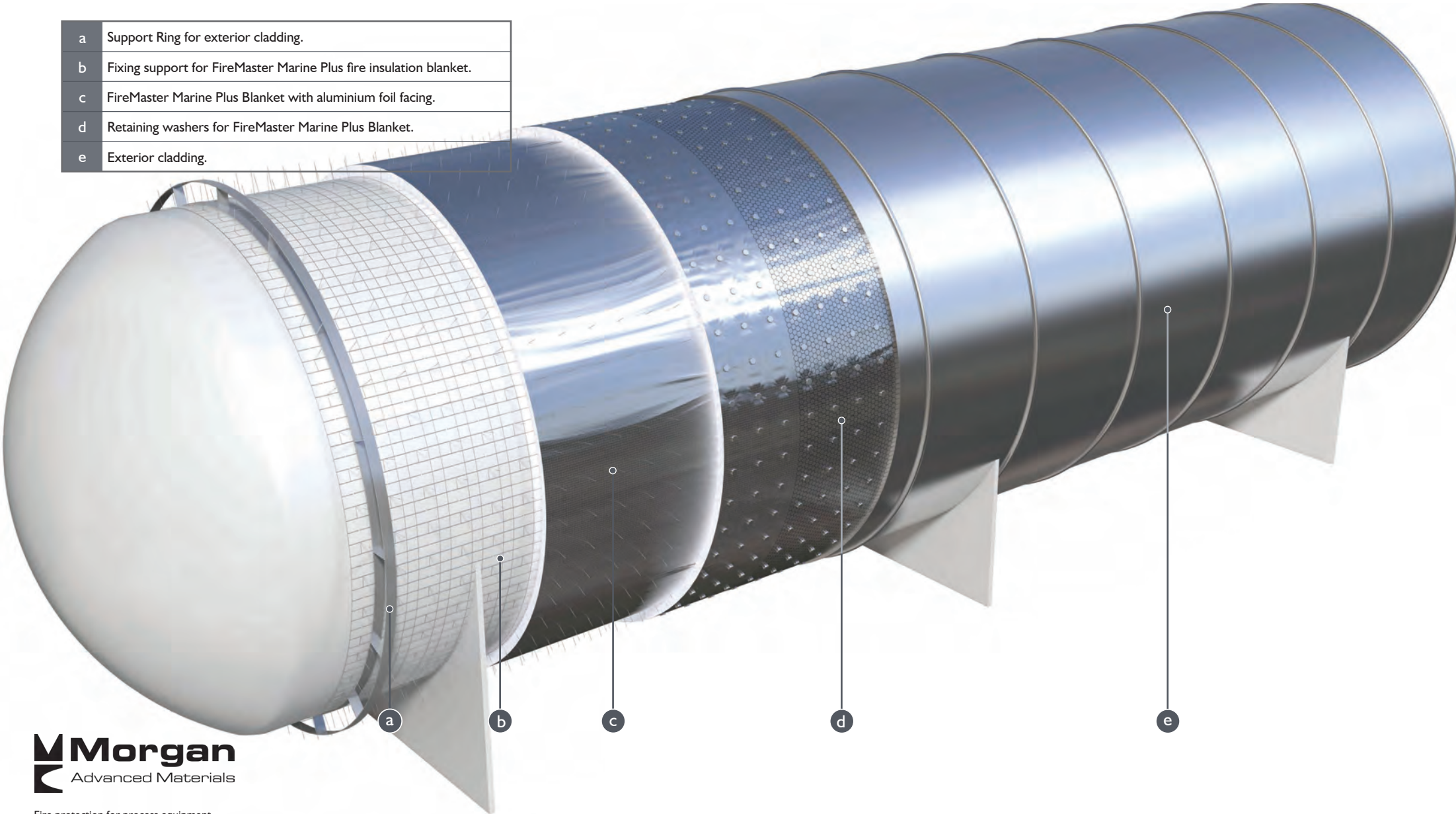

Hydrocarbon and Jet fire protection for process vessels - detail view

a	Support Ring for exterior cladding used on main body of vessel. Stainless steel 3mm thick 40mm wide strip with height adjusted to meet insulation thickness using 3mm up-stand steel sections at no less than 200mm centres. The support rings are placed over the blanket retaining mesh and clamped into place at their edge. If required, the cladding rings can be applied over a fibreglass tape to avoid direct contact with the vessel steel although this is not required for fire protection performance. Cladding support rings are normally spaced no more than 125mm from the cladding sheet edge and at 600 mm centres nominally. As the FireMaster® Blanket width is 610mm, a 600 cladding support ring spacing is most convenient. FireMaster Blanket should be tightly fitted into the support ring either by packing a separate strip or inserting the blanket edge into the ring void.
b	Fixing support for FireMaster Marine Plus Blanket. Welded mesh, stainless or galvanised steel 50mm x 50mm x 2mm. The mesh is cut and bent outwards to form a fixing pin for the blanket at 200mm centres. Individual sheets of mesh are attached together by twisting the edge strands of the mesh together. If necessary the mesh can be attached using steel banding straps for additional support.
c	FireMaster Marine Plus Blanket 128 kg/m ³ density with (optional) aluminium foil facing applied in a minimum of 2 layers. Thickness to be used is to be verified for each application in accordance with design fire, fire duration and specified critical temperature requirements. The system has been fire tested for 190 minutes in a Jet Fire to ISO 22899-1 standard using 88mm of FireMaster Marine Plus Blanket insulation achieving JF/Process Vessels/200/180 classification. Contact Morgan Advanced Materials for advice on thickness requirements for individual applications.
d	Retaining washer for FireMaster Marine Plus Blanket usually 38mm diameter friction-fit type. Galvanised or stainless steel. The cut mesh strand is bent over the washer to secure the washer.
e	Optional layer of wire mesh.
f	Exterior Cladding appropriate to the fire scenario. For Jet fire protection, 0.6mm 304 Grade stainless steel is used.

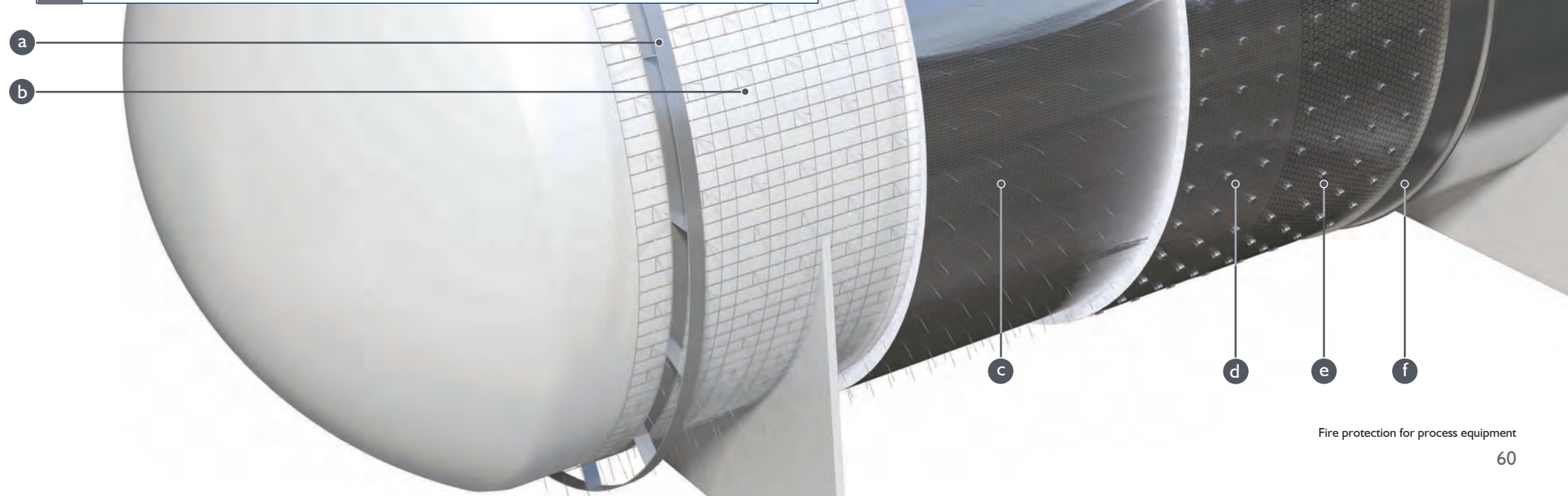

FireMaster® vessel fire protection system

Hydrocarbon and Jet fire protection for process vessels - detail view

a	Exterior cladding on dome ends of vessel. Segments have swaged edge seams. Grade of steel and fixing of the segment sections to each other is as outlined in (b) below. Cladding support rings are not normally required for dome end segments.
b	Exterior cladding for main vessel body, 0.6mm 304 grade stainless steel may be used for Jet Fires up to 190 minutes duration. Cladding edges to overlap by 75mm. The top overlapping cladding panel has swaged edges. (See detail drawing below right). Fixings used to join the cladding sections together are inserted centrally into the swage. Where swaged edges meet (e.g. vertical and horizontal edges), the swage is terminated at 75mm from the sheet edge to allow for a tight overlap. Fixing of cladding segments to be made with no. 8 stainless steel screws or 10mm diameter stainless steel rivets at 100mm spacing. Stainless steel banding straps 20mm wide at 200mm centres can be used for secondary support of the cladding if required, but do not form part of the fire protection system requirement. A mastic sealant may be used between cladding joints if required for weather protection purposes but is not a requirement for fire protection performance.

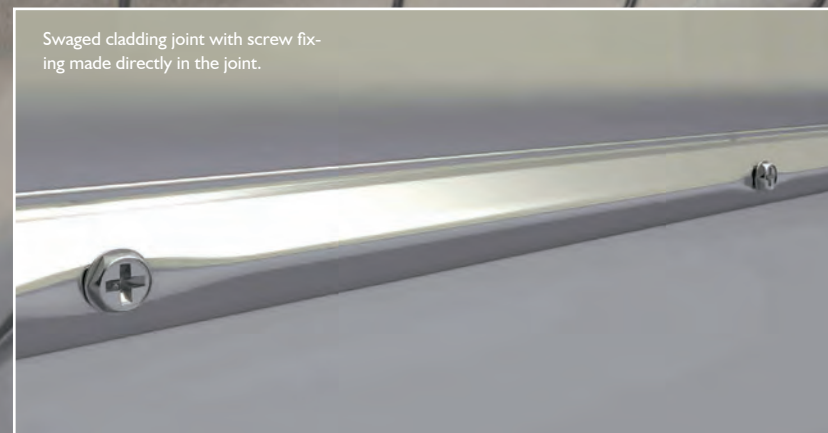



Explosion resistance testing of FireMaster[®] Process Equipment fire protection systems

Explosion resistance testing of FireMaster® Process Equipment fire protection systems



The following systems were tested for explosion resistance at the DNV-GL Spadeadam test site in 2015:

- FireMaster® Vessel Fire Protection System
- FireMaster RES System installed onto a 3 inch schedule xxs pipe
- FireMaster Pipe Fire Protection System
 - 3inch schedule 40 pipe insulated with two alternative insulation specifications:
 - 76mm FireMaster Marine Plus Blanket + 40mm of Microporous flexible (total outside diameter of pipe 322mm)
 - 38mm FireMaster Marine Plus Blanket + 76mm Microporous flexible (total outside diameter of pipe 306mm)



Pipes and RES system installed in explosion chamber prior to explosion testing.



FireMaster vessel system installed on back wall of explosion chamber prior to explosion testing.

Explosion resistance testing of FireMaster® Process Equipment fire protection systems

The specimens were subjected to two consecutive explosions with the following overpressures

Test	Average Overpressure (mbar)	Average Duration (ms)
1	430	170
2	500	170

After each test the specimens were examined and assessed for integrity of the fire protection system.

Test Sample	Assessment of Damage	
	Test 1	Test 2
FireMaster Pipe 1	Some deformation of the end caps	Some deformation of the end caps
FireMaster Pipe 2	Some deformation of the end caps	Some deformation of the end caps
FireMaster RES	Some deformation of the end caps RES box rotated 90°	Some deformation of the end caps. Loss of some rivets near centre of pipe
FireMaster Vessel System	No damage or deformation of FireMaster Blanket	No damage or deformation of FireMaster Blanket



RES system after second explosion test.



FireMaster Vessel system after 2nd explosion test. No damage occurred to the cladding. An inspection of the insulation was made after removal of the cladding and no damage or compression of the insulation thickness was noted.



Pipe system after second explosion test.



FireMaster[®] structural steel fire protection



FIRE PROTECTION

FireMaster® structural steel fire protection

Fire insulation to steel beams and columns



FireMaster Blanket and FireBarrier™ products provide fire insulation to steel beams and columns to ensure they maintain load-bearing capacity in a fire, thus preventing collapse of the structure they are supporting.

Traditionally, fire insulation is required to ensure the steel temperature does not exceed 550°C, the point at which steel retains 60% of its room temperature structural strength. However, different maximum temperatures are often specified, taking into account temperature profile and load on the sections. Critical temperatures ranging between 400°C and 620°C are common, with 400°C widely used in the offshore industry.

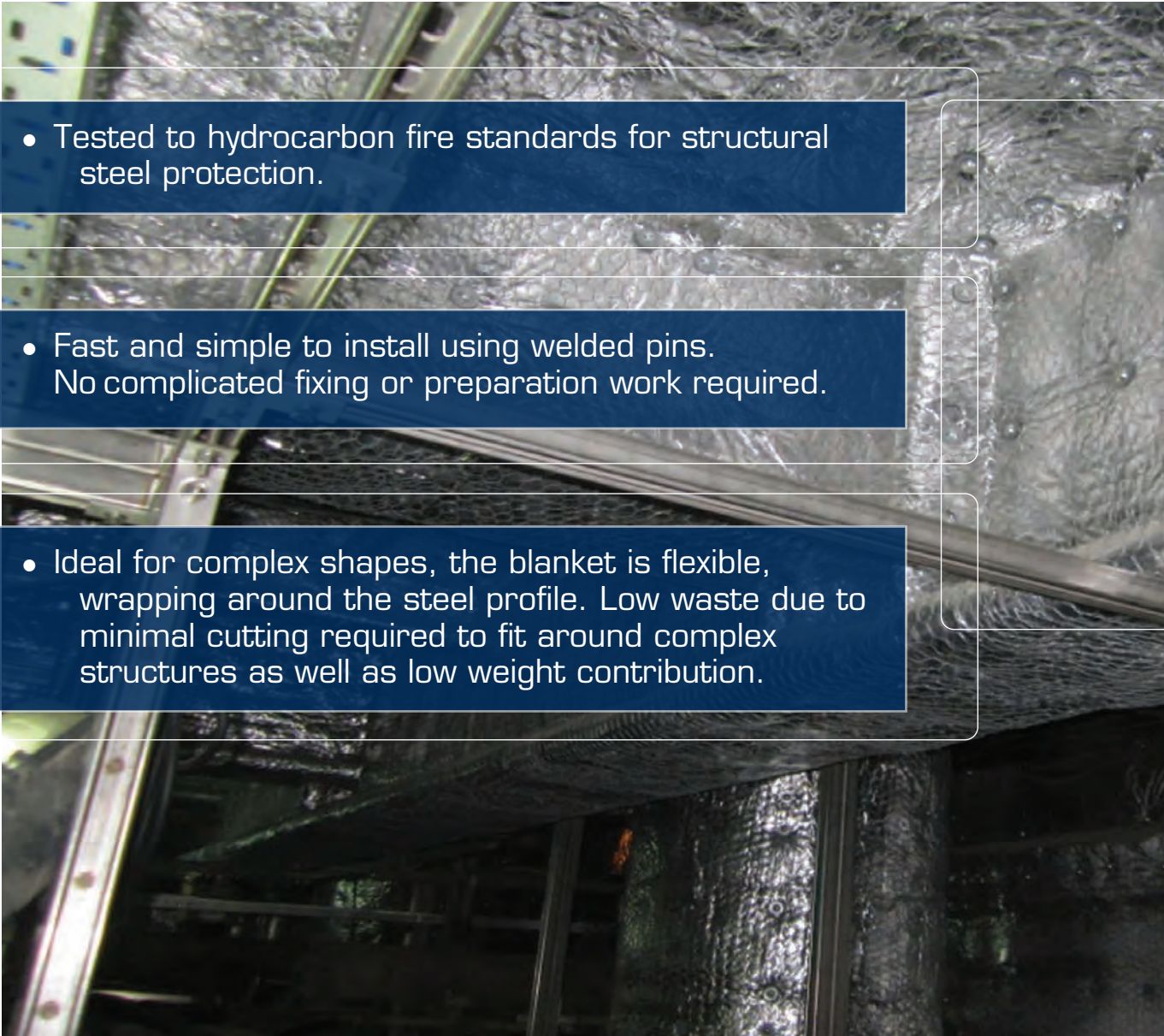

• Tested to hydrocarbon fire standards for structural steel protection.

• Fast and simple to install using welded pins. No complicated fixing or preparation work required.

• Ideal for complex shapes, the blanket is flexible, wrapping around the steel profile. Low waste due to minimal cutting required to fit around complex structures as well as low weight contribution.

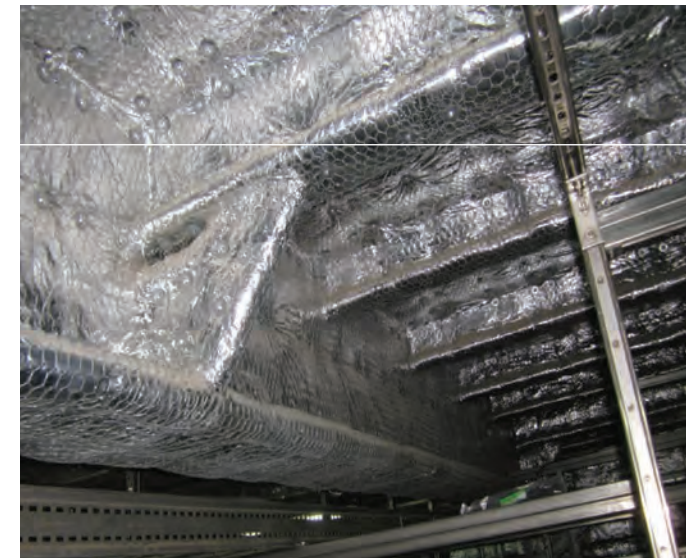
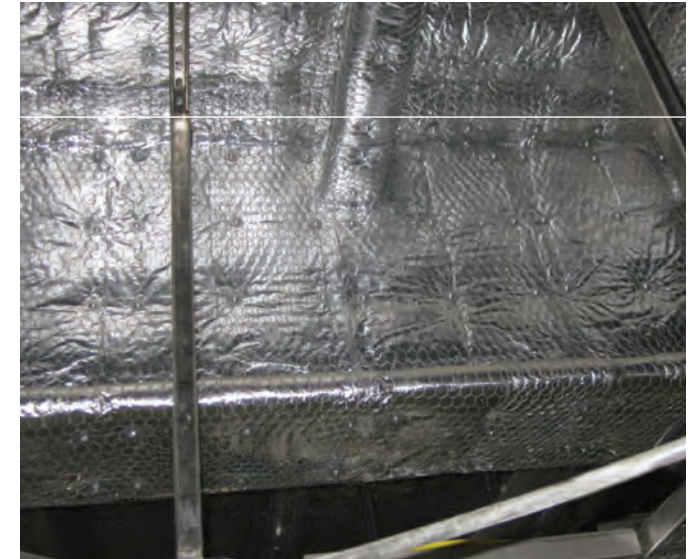

FireMaster® structural steel fire protection

Fire insulation to steel beams and columns

a	Steel beam or column.
b	FireMaster Marine Plus Blanket 128 kg/m ³ density. The blanket is applied following the profile of the steel section as illustrated. Two layers are installed with joints between each layer offset by approximately 300mm. Joints between adjacent blankets are tightly butted together. For thickness requirements see 'FireMaster Structural Steel Protection: Guide to Specification and Certification' section.
c	Steel fixing anchors copper coated mild steel 3mm diameter. Anchors are spaced at 150mm centres with joints between blankets spaced at the mid-point of the anchors, i.e. 75mm.
d	Exterior cladding where required. For exterior weather exposed areas, the use of 3M Venture Clad 1579 GCW-WM is suggested.

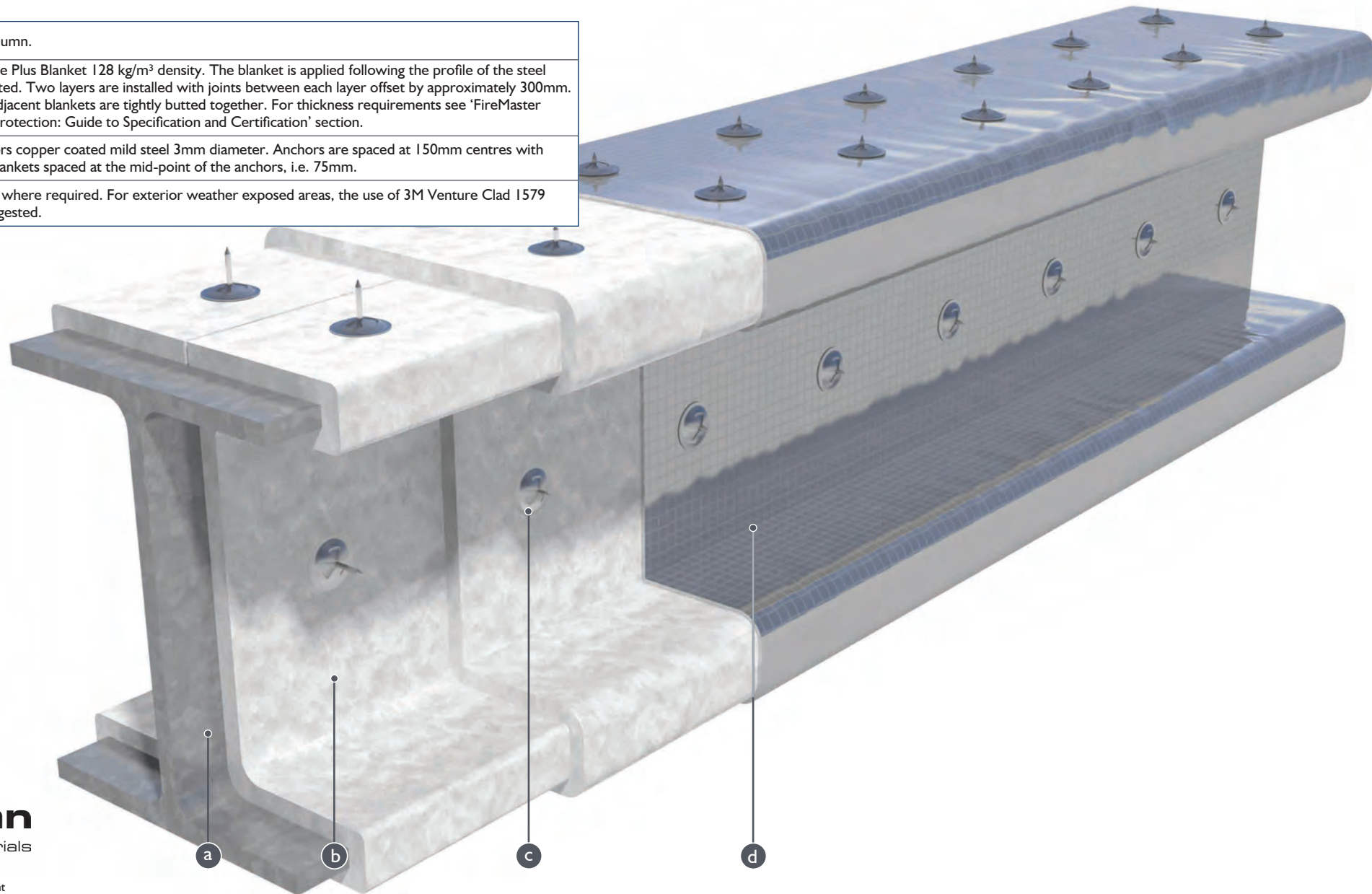

Fire insulation to steel beams and columns - alternative fixings

a	Steel beam or column.
b	Steel fixing anchors copper coated mild steel 3mm diameter. Anchors are spaced at 150mm centres with joints between blankets spaced at the mid-point of the anchors, i.e. 75mm.
c	FireMaster Marine Plus Blanket 128 kg/m ³ density. The blanket is applied following the profile of the steel section as illustrated. Two layers are installed with joints between each layer offset by approximately 300mm. Joints between adjacent blankets are tightly butted together. For thickness requirements see 'FireMaster Structural Steel Protection: Guide to Specification And Certification' section.
d	Exterior cladding where required. For exterior weather exposed areas, the use of 3M Venture Clad 1579 GCW-WM is suggested.

For large steel beams additional fixing anchors are used within the web. The maximum spacing for anchors is 300mm.

a

b

c

d

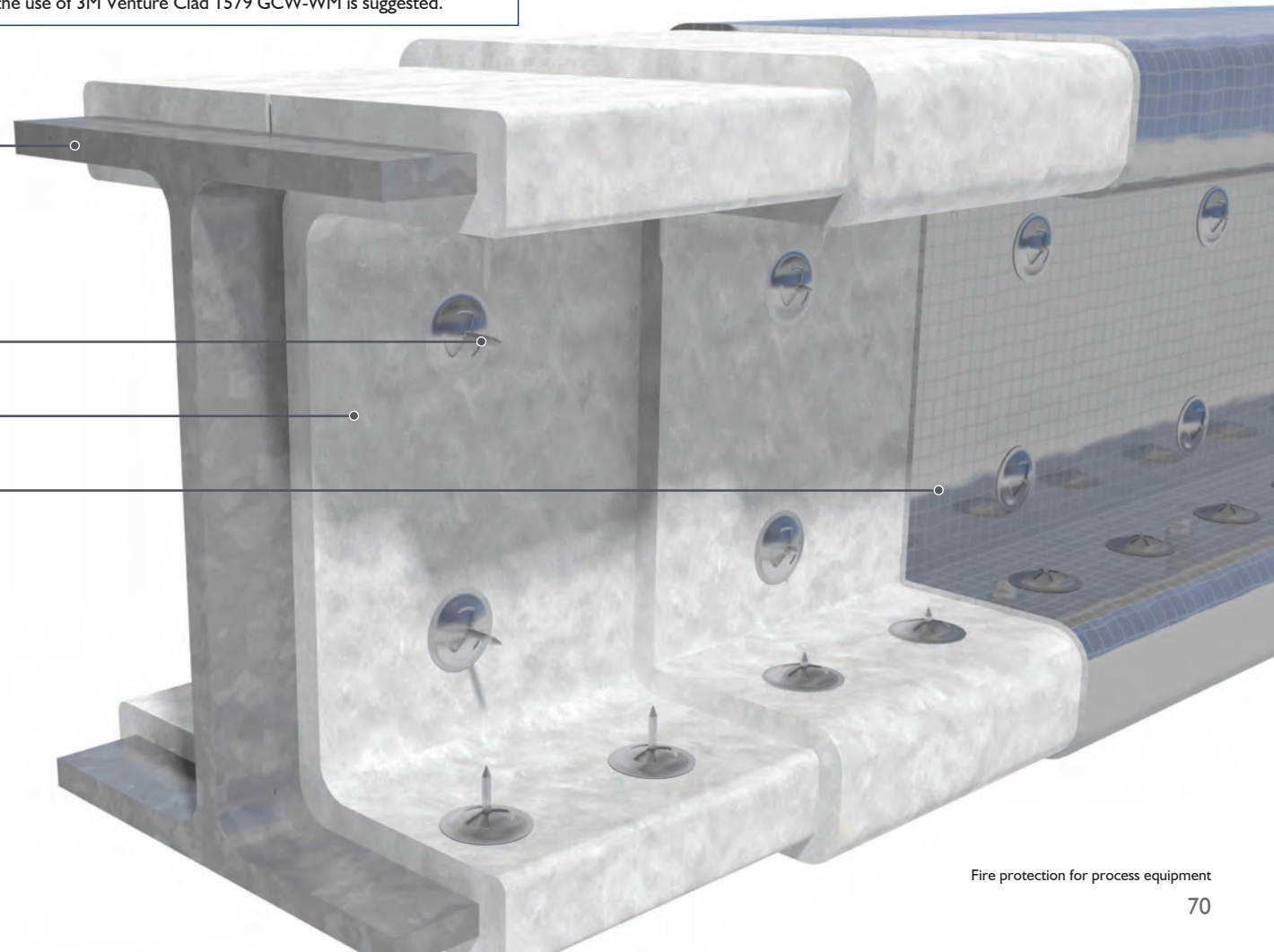

Structural steel fire protection system

A guide to specification and certification

FireMaster® structural steel fire protection system

The thickness of insulation that is required to be applied to steelwork to provide fire protection will depend on a number of factors. These are:

1. Fire load and duration
2. Critical temperature specified for the steel; i.e. the maximum permitted temperature for the steel section during the fire
3. The “section factor” of the steelwork; a relationship of external surface exposed to fire to the steel sectional area

Critical steel temperature

Steelwork is insulated against fire to maintain its temperatures below a specified critical temperature limit to ensure its loadbearing function is maintained. The limit usually commonly applied to supporting structural steel offshore on for example, living quarters is 400°C for a 60 minute period.

This limit is also often applied to process plant equipment. Other temperature limits may be applied depending on the function of the structure. For example support steelwork for emergency shutdown valves is usually limited to a maximum temperature of 200°C for 60 minutes. Secondary steelwork in process areas may have a maximum steel temperature of 550°C specified for 60 minutes.

Section factor

The section factor relates the surface area of the steel section exposed to fire to the amount of steel in the section cross-sectional area available to absorb heat from the fire. The surface area of the fire-exposed section divided by the cross-sectional area is defined as the ‘section factor’; ‘Hp/A’ or ‘F/A’. Steel sections with large section factors will exhibit faster temperature rise in a fire than those with smaller section factors as the ratio of area receiving heat to the mass of steel available to absorb that heat increases. Section Factors are calculated by dividing the external fire-exposed perimeter of the steel section by its cross sectional area.

The example, below, compares the section factors of two different sized steel columns.

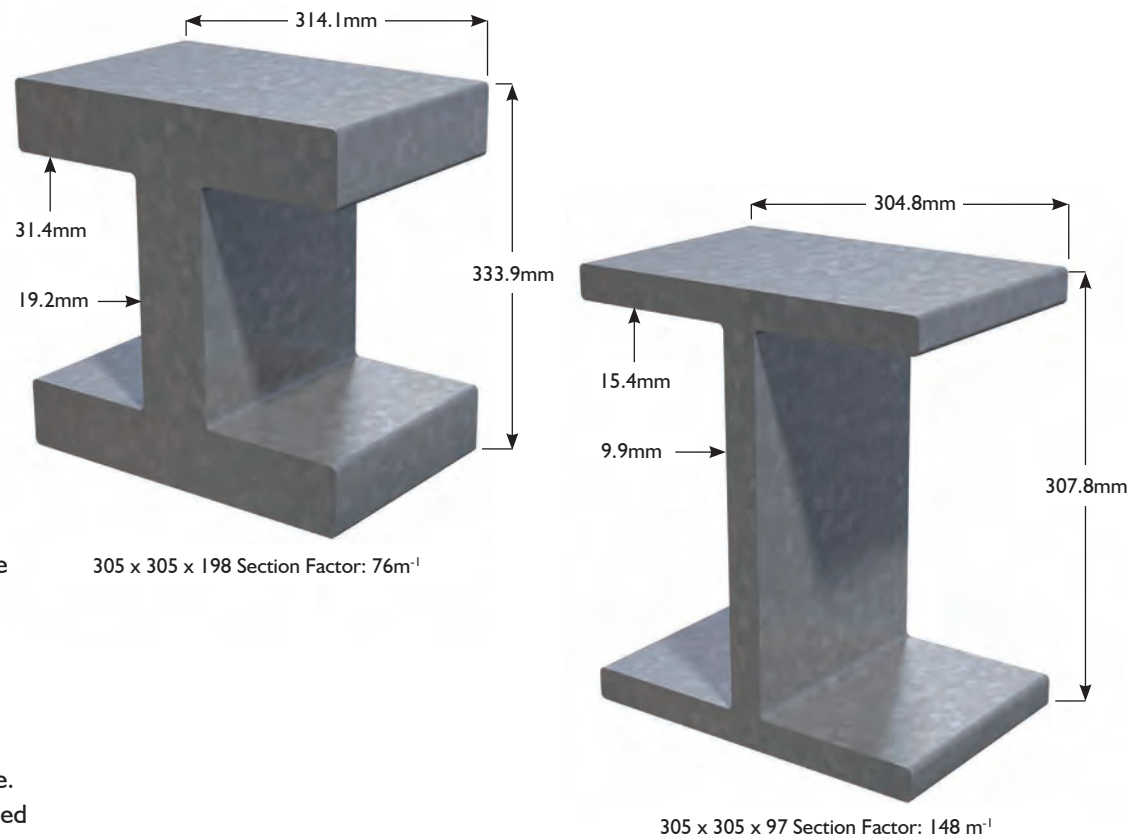

Section factor (m ⁻¹)	Insulation thickness required to maintain steel temperature to 400°C for two hours in a hydrocarbon fire
76	50mm
148	81mm

The table above, illustrates the effect of section factor on insulation thickness for two different sized steel sections.

A guide to specification and certification

Fire testing of structural steelwork fire insulation is designed to relate section factor to insulation thickness for a variety of failure temperatures and this requires a large variety of sections to be fire tested. FireMaster® Marine Plus blanket has been fully tested in order to generate the required thickness tables in accordance with Annex E4 of EN 13381-4 fire test procedure for structural steelwork in hydrocarbon fires.

This test standard also requires loaded beams to be fire tested in order to assess the 'stickability' of the insulation system as the beam deflects under load with increasing temperature. This is to ensure the insulation system has adequate integrity for use.

In order to assess any impact of the beam deflection on the insulation system, identically insulated reference non-loaded columns of the same section factor are also tested to allow temperature rise data to be compared in loaded and unloaded conditions.

Fire load and duration

The heat flux or temperature to which the steel is exposed will influence the thickness of insulation required for fire insulation. From the fire tests, tables are constructed using multiple linear regression analysis of the fire test data to relate fire exposure time, section factor and critical temperature to insulation thickness.

FireMaster structural steel system fire testing and certification

The FireMaster structural steel system is testing in accordance with EN 13381-4 method using the hydrocarbon fire temperature/time curve specified in EN 1363-2 for protection periods up to 240 minutes and is Type Approved by Lloyds Register. Testing for cellulosic fire protection of structural steelwork has also been carried out in accordance with EN 13381-8 method with Lloyds Register Type Approval for up to 180 minutes.

Insulation thickness requirements for hydrocarbon fire protection of steelwork

The table on page 64 shows the variation of thickness with section factor for hydrocarbon fire protection of structural steel with a critical temperature of 400°C for various time periods.

For other critical temperatures and time periods reference can be made to the Lloyds Register Type Approval certificate.

Additionally Morgan Advanced Materials provides a software package 'SectionWizard' to allow straightforward access to the fire test approved thickness data without the need to calculate section factors or look up tables, see page 74 for further details.

A guide to specification and certification

Example of thickness requirements for structural steel fire protection in hydrocarbon fires

The table below illustrates the required thickness of FireMaster Marine Plus Blanket to ensure a critical steel temperature of 400°C is not exceeded for time periods in the range of 1 to 4 hours. For other critical temperatures please refer to the LLOYDS Register Type Approval certification or use our SectionWizard software.

Section factor m ⁻¹	Minimum thickness (mm) of FireMaster Marine Plus blanket to ensure a critical steel temperature of 400°C is not exceeded				
	60 minutes	90 minutes	120 minutes	180 minutes	240 minutes
70	50	50	50	69	91
75	50	50	50	73	96
80	50	50	52	77	101
85	50	50	55	80	106
90	50	50	57	84	110
95	50	50	60	87	114
100	50	50	62	90	119
105	50	50	65	94	123
110	50	52	67	97	127
115	50	53	69	100	130
120	50	55	71	102	134
125	50	57	73	105	137
130	50	58	75	108	141
135	50	60	77	110	144
140	50	61	78	113	147
145	50	63	80	115	150
150	50	64	82	118	
155	50	65	83	120	
160	50	67	85	122	
165	50	68	87	124	
170	50	69	88	126	
175	51	70	90	128	
180	52	71	91	130	
185	52	72	92	132	
190	53	73	94	134	
195	54	74	95	136	
200	55	76	96	138	
205	56	76	97	139	
210	56	77	99	141	
215	57	78	100	143	

Section factor m ⁻¹	Minimum thickness (mm) of FireMaster Marine Plus blanket to ensure a critical steel temperature of 400°C is not exceeded			
	60 minutes	90 minutes	120 minutes	180 minutes
220	58	79	101	144
225	58	80	102	146
230	59	81	103	147
235	60	82	104	149
240	60	83	105	150
245	61	84	106	
250	61	84	107	
255	62	85	108	
260	63	86	109	
265	63	87	110	
270	64	87	111	
275	64	88	112	
280	65	89	113	
285	65	89	114	
290	66	90	114	
295	66	91	115	
300	67	91	116	
305	67	92	117	
310	68	93	118	
315	68	93	118	
320	69	94	119	
325	69	94	120	
330	69	95	120	
335	70	96	121	
340	70	96	122	
345	71	97	122	
350	71	97	123	
355	71	98	124	
260	72	98	124	

SectionWizard Software

Morgan Advanced Materials offers technical support services to assist specification of our products. We use approved finite element packages to calculate fire insulation requirements for applications that cannot be directly addressed with fire testing alone. These calculation tools are used to supplement our existing fire testing and certification.

Available to all of our customers is the software package 'SectionWizard' (for PC only*).

This allows easy and fast specification of fire insulation requirements to steelwork or pipe sections. The software package is directly linked to our fire testing for steel sections and pipes and allows rapid specification of thickness requirements based on fire scenario, duration, critical temperature and steel section size.

Standard steel section or pipe dimensions are included in a database thus eliminating the need for calculating section factors and then referencing standard tables of thickness. Specification of fire insulation requirements can be carried out in a short time period and always in accordance with the relevant Type Approval certificate.

To obtain a copy of SectionWizard, contact your local Morgan Advanced Materials office.

* Compatible with Windows 7 (32 or 64 bit) Operating Systems and higher

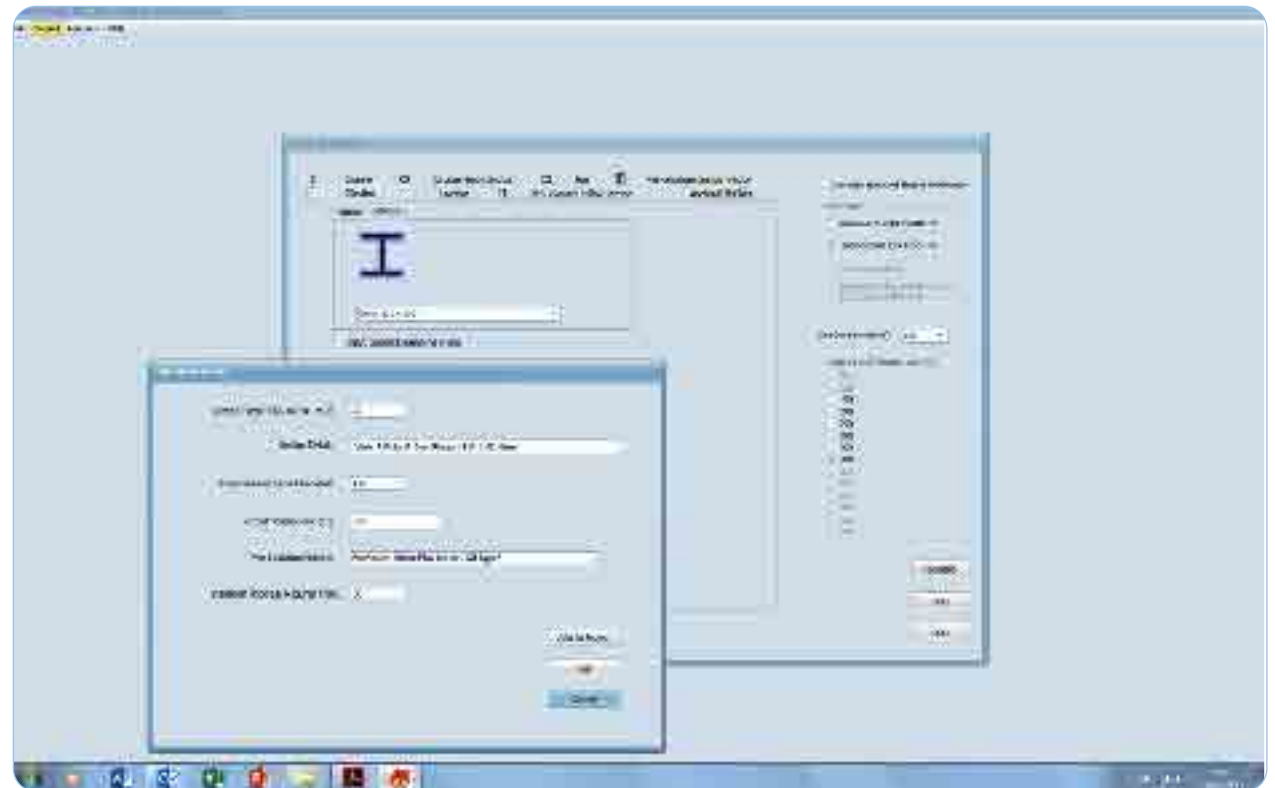

Morgan Advanced Materials

Significant trends shape our modern world, accelerating the demand for new and more sustainable advanced materials.

At Morgan Advanced Materials, we use advanced carbon and ceramics materials to support the move to a more sustainable world. Our people are driven to solve complex customer problems: from managing heat and enabling greener technologies, to supporting improved medical diagnostics and protecting life.

Our purpose is 'to use advanced materials to make the world more sustainable, and to improve the quality of life'. This purpose is underpinned by our safe, ethical and inclusive culture, embraced by our 7,800 employees spanning over 25 countries. Working across many industries and in a number of markets, we deliver the materials science and technologies the world needs now.

Our Strategy

We are a global advanced manufacturing organisation with leading capabilities in three areas: materials science, application engineering and customer focus.

Our Business Model

We operate as two global divisions and five global business units. We empower our global business unit teams, giving them considerable autonomy and enabling them to act quickly and support their customer needs. Our broad manufacturing footprint enables us to supply customers locally from a short supply chain.

www.morganthermalceramics.com

www.morganadvancedmaterials.com

Morgan Advanced Materials plc
Quadrant, 55-57 High Street
Windsor, Berkshire, SL4 1LP
United Kingdom

For all enquiries, please contact our specialist sales and marketing offices:

Americas

marketing.tc@morganplc.com

Asia

asiasales@morganplc.com

EMEA

sales.tceMEA@morganplc.com